

ENERGY MANAGEMENT TECHNIQUE IN CHARGING SYSTEM IN ELECTRICAL VEHICLE: CHALLENGES & APPLICATION

¹Vishal Gangwar, ²Nisar Chahar

¹M.Tech Scholar, ²Head of Department

Department of Electrical Engineering, CBS Group of Institution, Jhajjar, Haryana

Abstract: In India, the demand for oil resources is increasing at a faster rate than in other nations. By the end of 2040, the estimated demand for oil resources is expected to reach 9.8 million barrels per day. 65% of the increase in demand may be attributed to automobile mobility. Estimates of 260 million cars, 185 million two-wheeled and three-wheeled vehicles, and 30 million trucks are also predicted. Rather than reducing global warming, however, greenhouse gas emissions remain a major source of concern today. According to a decision made by the UN Security Council, the global temperature should be lowered. By 2050, greenhouse gas emissions must be decreased by at least half compared to what they were in the year 2000. As a result, the automotive industry is searching for a more environmentally friendly alternative. Electric vehicles (EVs) emit no pollutants and are the greatest solution.

There are often a number of start-stop-go situations that require both average and instantaneous power delivery throughout driving cycles. When it comes to everyday car power requirements, batteries still outperform other more advanced energy storage systems (ESSs). However, the downsides, such as higher thermal heating, starting and operating costs, time for recharging, and reduced travel distance, power density, and working life duration, persist in batteries. Because of this, relying solely on battery power to power a vehicle is inefficient. The above-mentioned issues can be alleviated by the use of hybrid electrical sources. In order to meet urgent vehicle power requirements, a hybrid ESS (Ultracapacitor, or UC) with a longer life cycle and improved power density has been included.

Keywords: Electric vehicle; battery; ultracapacitor; hybrid energy storage system; energy management strategy

1. INTRODUCTION

The introduction of Electric Vehicle (EV) ensures a significant revolution in human life. The number of EV users is estimated to be more than one billion numbers by the year 2010. The yearly manufacturing of EVs keeps growing, as per the OICA statistics about 90 million EVs were manufactured in 2015. The Internal Combustion Engine (ICE) vehicles are becoming the most basic part of modern life. ICE is the largest source for the liberation of greenhouse gases. Roadways contribute around 90% of carbon-monoxide, 40% of nitrogen oxide, and 25% of carbon-dioxide emission [1]. Atmospheric air effluence considerably harms human health. It is found in WHO reports that almost 7 million human being deceased by the year 2012 because of air contamination. Today's anxiety about the atmospheric situation, in exact exhaustion of greenhouse gases emissions, motivates the automotive manufacturers to refurbish their attention in EVs.

Primarily EVs are having lower driving distances and poor vehicle performances because of its limited power and energy capacities of energy storage systems. In the past few decades, global environmental issues and poor efficacy of the ICE based passage have improved the curiosity in vehicle electrification. Recently, the United States government's department of EV took an initiative to offer funding for the growing battery technologies, new extensive power semiconductor devices and power electronics technologies. New opportunities are set for the electrified transport. Those opportunities helped to minimize EV's Energy Storage Systems (ESSs) costs to half of its cost over the last few years. The other characteristics of batteries such as its energy and power handling capacity, its durability must also be improved in addition to batteries cost. This may further ensure the development of EVs worldwide [2].

All EVs are driven fully on electrically powered, usually use single or many electrical motors with a huge ESS. The charging of battery is associated with plugging the vehicle chord either at home grid or private charging locations. EVs are free from fuels since they do not rely on ICEs. Hybrid Electric Vehicles (HEVs) and Plug-in HEVs depend on dual ESSs, usually, ICE and battery-powered electrical motor driven vehicle. ICE may also be utilized to charge the battery. In the case of HEV, the battery pack used for propulsion must be replaced once it is drained since it cannot be plugged in for charging [3].

EVs hold numerous benefits above the conventional ICE vehicles. To begin with, the energy efficiency of EVs is far more. Around 21% of the gasoline energy can be converted usefully as driven power whereas in the case of EVs around 62% of battery energy can be utilized to drive the vehicle wheel. Then, EVs are clean, green and eco-friendly. EVs are subjected to zero tailpipe release of greenhouse gases. EVs promises for silent and smooth traveling since it uses electrical machines. Lastly, it necessitates less repairs and maintenance than ICEs [4].

II. CHALLENGES IN EV DEVELOPMENT

EV faces several challenges associated with ESSs. EV can have a traveling distance of 50 to 200 miles per charging of its storage device whereas ICEs can have the capability of traveling up to 300 miles per fueling. Most of the EVs possess heavier batteries to make the vehicle run for longer range but that may lead to the considerable usage of vehicle space. Also, the vehicle cost related to high rated battery is more. In general, the average life span for any type of batteries is around 10 years or less. Vehicles are subjected to frequent starts and stops as per the driving conditions. It leads to instantaneous charging and discharging of battery. This frequent

charging and discharging in batteries may further deduct the battery lifetime of batteries [5]. Fueling the full tank for an ICE may take just about few minutes whereas, for an EV, it takes hours together for a single full charging of a battery.

At present, the automobile companies use Li-ion batteries as their main ESS to meet out the vehicle demanded power and energy. EVs recently prefer the batteries with better performance i.e. with higher energy density and longer life. In existing EVs, the ESSs are huge sized to provide higher energy and avoid undesirable reduction in the lifetime of batteries owing to motoring and braking. Instead of using the main source alone as ESS, an extra source called an auxiliary source can be introduced with main ESS may result in complementary advantages of both in EVs. There exists different ways of hybridizing ESSs in EVs and HEVs. to make use of its complementary features. Some of the ways of hybridization are 'battery – UC', 'fuel cell – UC – battery', 'battery – fuel cell' etc. This thesis mainly concentrates on battery – UC hybridization.

Batteries possess higher energy densities and UC has higher power densities. So an integration of both can aid better for average and transient driving power demands required by the EVs. The EV performances are better in battery – UC hybrid vehicle than battery alone powered vehicle. It can also has the capability of ensuring less weighted and small-sized ESS since battery is not meant for full load demand. It is taken care of by an auxiliary source UC. Battery – UC hybridization can also improve battery lifespan since the peak demand in power can be supplied by UC. It also has the potentials for improved transient performance and relief from the battery's internal temperature rise [6, 7].

Energy Management Control Strategy (EMCS) plays a significant concern in hybridization since it has a considerable impact on the HEVs performances. An optimum EMCS must offer several benefits like reduction in the consumption of fuel, greenhouse gas emissions and increased driving performances of the vehicle.

HEV is hybridization between ICE and battery powered electrical motor. EMCS in such vehicles is necessary to divide the power among ICE and motor. The most important objectives of EMCS in those HEVs are related to the reduction in emission of gases and to optimize the consumption of fuel. In the case of EV, battery and UC hybridization is meant for sharing the power demand among battery and UC. EMCS in those vehicles must be designed to have reduced energy consumption from battery for the improvement in vehicle traveling range and to minimize the battery stress for increasing the lifespan of battery. However, this thesis focuses mainly on hybridization between battery-UC, the work, and its design features that can be implemented to any other way of hybridization systems.

III. Related Work

The basic configuration of the battery power electric vehicle is as shown in Figure 1.1 [8]. The essential parts in battery powered EVs are its ESS, power electronic converters and electric traction motors. Battery pack, fuel cell, and UC are the ESSs used in vehicle applications. The control of power among the ESSs is carried down by the electronic control unit (ECU). The effective working of ESSs depends on its EMCS.

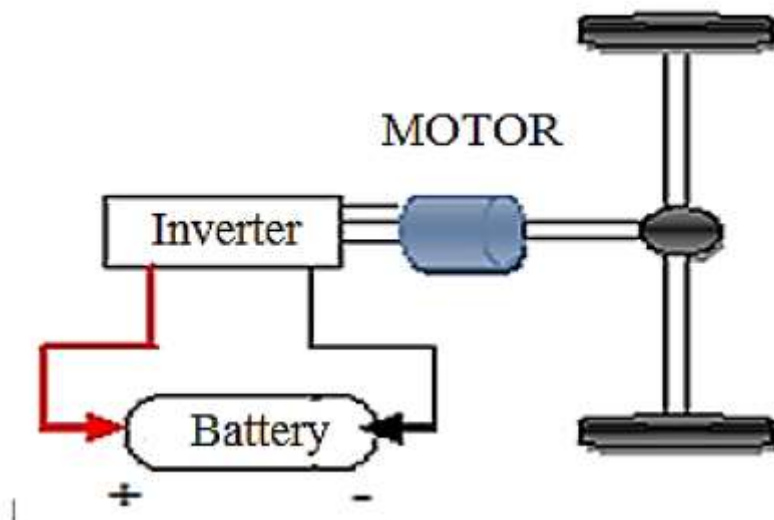

Figure 1.1 Configuration of Battery Powered Electric Vehicle

3.1 Energy Storage Technologies

Amongst several critical factors battery's state of charge (SOC) acts a key part. Measuring the battery's SOC directly is not possible. It strongly believes in the chemical composition. Modeling of a battery cell is essential for the proper estimation of SOC. Whenever the battery is exposed to overcharging or over discharging; it can highly damage the internal components of the battery. Those charging and discharging characteristics of batteries may lead to the reduction of its lifespan. Hence it is important to prevent the batteries from those damages. There are many emerging techniques available for estimating the battery SOC and each of them possesses its pros and cons.

Internal Resistance Model (IRM) could able to define the power handling capacity of the battery with respect to Open Circuit Voltage (OCV). Battery's ohmic resistance is designated by R_i . The other important models are RC model and Thevenin's circuit model. The current represented in negative sign denotes the discharging current [9].

Constant current pulse charging and discharging tests are generally used for obtain static parameter by knowing the immediate change in battery voltage and the step current applied. Dynamic parameters involve in time constants, hence uses the battery voltage long response as segment to estimate the model dynamic parameters. A French scientist, Gaston Plante developed a most interesting battery called lead acid by the year 1859. Positive electrode be made of lead oxide (PbO₂) negative electrode be made of lead (Pb). The battery electrodes are separated from each other by the use of Sulphuric acid (H₂SO₄). Here, R_o is designated as ohmic resistance of a battery cell. C_n specifies the nominal capacitance. V_{oc} signifies the open circuit voltage. C_s denotes the discharging current owing to the effect of electrode material. V_{cs} is the surface capacitor voltage. R_e , R_t , and R_s are the end, terminal, and surface resistance respectively. C_p and R_p are the capacitance and resistance of the electrochemical polarization. R_i is denoted as an input ohmic resistance.

In most cases, batteries are subjected to a very high intermittent load power. That may lead to bigger and heavier batteries with shorter lifespan. However, the customer's attraction is always towards lead acid ESS because of its cost. Most of the traded batteries are handy and portable. The performance of Li-ion in the current scenario is higher because of its lesser mass, higher energy density, least self-discharge, appreciable life cycle, and better output voltage. The most widely used cathodic material in Li-ion batteries is LiCoO₂, LiMnO₄, and LiNiO₂. The positive electrode of Li-ion batteries is made up of graphite.

Speedy charging of battery is necessary in all applications. Nickel-cadmium battery has the capability of doing fast charging. The electrode plates of the Ni-Cd battery is coated with metallic Cd and nickel oxide hydroxide NiO(OH). It also has certain other potentials such as reduced battery heat, longer storage capability, and life duration. Harmful to the environment is the major problem arises in NiCd battery.

Active materials required for the flow batteries are stored externally. Cell stacks are capable of circulating the active materials into the battery whenever it is required. An example of such a battery is zinc/chlorine. Here, chlorine is distributed into the battery. Few further other flow battery is also reviewed under this chapter. The invention of Vanadium REDOX Flow Battery (VRFB) is made in 1984. (+)ve electrode is coated with V⁴⁺/V⁵⁺ and the (-)ve electrode is coated with V²⁺/V³⁺. Here, H₂SO₄ is acting as an electrolytic medium. Its basic characteristics include efficiency of (70%-85%), specific energy of (10 Wh/kg – 30 Wh/kg) and lifespan of about (12000 cycles – 14000 cycles) [11].

Another flow battery is Polysulfide bromine which possesses a double combination of an electrolytic solution. They are NaBr and Na₂S_x. Exchange membrane is made up of a polymer type of chemical [12]. Its basic characteristics include efficiency of (60%-77%), specific energy of (10 Wh/kg – 50 Wh/kg) and lifespan of about (2000 cycles).

There exist various forms of Electric Double-Layer Capacitors (EDLCs). UC works unlike the normal capacitors since they ensure very high capacitance. Also, the energy density of UC seems to be very high than normal capacitors. The table reveals the distinct electrical characteristics of the battery and UC. Whenever the vehicle is subjected to sudden motoring action, it requires more current from the source. UC might power such high current required as well as very high voltage. Hence UC is exposed to frequent charging and discharging which may result in quick changes in SOC of UC. The operating temperature always lies between the range of -40° C to +70° C in UC. Which is comparatively very high than any other batteries. Using UC alone in EV does not offer a better solution. Hence a battery-UC hybridization can have good performance in EV applications. Figure 1.3 (a) signifies the electrical characteristics of batteries and UC [13].

3.2 Electric Motors

Several kinds of electric motors are being utilized in EV applications. In numerous conventional EVs, Direct Current motors are greatly used but then owing to the recent scientific improvements many other special electrical machines are also employed.

Conventionally, DC motor seeks greater attention in the automobile sectors because of its simplest construction and flux and torque decoupling. Presence of brushes and rings leads to repairs and maintenance issues in DC motor. In the case of operations under field weakening mode of separately energized DC electrical motor, the flux and torque decoupling is better. Therefore strong recommendations for DC motors are observed in EV applications. The torque required by the motor shaft is too high; the motor gets operated under very low speed with a continuous supply of power [15]. These motors are heavier in weight and very expensive. It is not suited for a single transmission gear systems. Overall DC motors possess less efficiency, heavy-weighted, least reliable and more costly. Under low speed operation, DC motor has better torque handling capability.

AC motors have certain good features than DC motors. They are highly reliable and less repairs and maintenance. EVs are looking for wide-ranging of speed and its control. Speed of the induction motors can be controlled by field orientation and vector control. It can also run better with enhanced dynamic characteristics. The efficiency of the induction motors is considerable very less when it is forced to run at very high speeds. It is noted that its efficiency is reduced considerable if it is operated at high speed. The attractiveness of the induction motor mostly belongs to its enhanced dynamic characteristics, rugged construction and reliable working [16].

ABB established a special electrical machine called Synchronous reluctance which creates attention on the development of EV performance. When the design and working of synchronous reluctance is compared with induction motors, synchronous reluctance motor with a frequency converter requires less maintenance and cost.

An innovative rotor design of this motor has contributed the least losses and high power. The combined features of permanent magnet DC motor (PMDC) and induction motor can be obtained from synchronous reluctance. Frame size of SRM is less than the induction motor [17].

Switched reluctance motor (SRM) needs a single magnetic field which is considered to be a distinct feature than other motors. Based on the position of minimum reluctance, a torque is produced. Choice on the number of stator-rotor poles and frame size is the key part of the design procedure of SRM. The number of stator-rotor poles must be high to decrease the noises. This makes a challenging impression in the field of power electronic controllers.

Robustness in operation, less expensive and simplest construction is the major advantages of SRM. Though it possesses many advantages, more acoustic noises and the requirement of special power controllers are some of the disadvantages in SRM [18].

3.3 Hybrid Energy Storage System Topologies

In common, the design of hybrid ESSs relies on three distinct conditions: operating ranges of UC voltage, restrictions in power controllers (energy losses and cost associated problems) and Requirement of low voltage rated battery packs. Various researches are ongoing in the fields of the above conditions.

Active topology contains dual DC/DC power electronic converters between UC and battery bank respectively as depicted in Figure 1.5 (a). It promises for higher accuracy while splitting the power among the power sources. The controls of power between the sources are well managed in active topology. It is highly flexible in operation and has better stability. Fluctuation current and voltage related issues can be best solved by this topology. The major downsides found to be the control system complexity and usage of more number of semiconductor switches.

A DC/DC boost converter is linked in series with UC. The power that UC needs to be supplied can be effectively controlled in this topology whereas the remaining power that battery supplies is uncontrollable. Less ripple voltage is maintained in the DC-link line. The rating of the power converter used in this topology must be higher rated since it must meet out the peak power required by the vehicle.

3.4 Energy Management Control Strategies

The foremost challenge in HEVs is efficiently dividing the demanded load among the main source (battery) and an auxiliary source (UC). The splitting of power between the ESSs must be optimum enough for the proper performance of the vehicle. The control strategies depend on many control equations that rely on several controlling factors like travel length of the vehicle, driver's driving behavior, the SOCs of the ESSs, electric motor drives, etc. The uncertainties in driving a vehicle may make the factors to affect the performance still worse. In the case of real-world driving situations, the travel length of the vehicle, the stresses in batteries and many other factors are not known. Those are some of the restrictions for designing the EMCS.

The foremost intentions in the hybridization of ESS are to split the power among ESSs to meet out the demanded power, maintain the charges in ESSs, extend the lifespan of the battery and increase vehicle efficiency. A better EMCS must able to manage the power split-ups effectively.

Various EMCSs have been suggested and analyzed in many literatures for splitting the power between ESSs. Several different sources of power such as battery with ICE, battery with UC, battery with fuel cell, battery, and fuel cell with UC, etc. are hybridized. Their merits and demerits are also discussed in this section.

The major categories of ESS proposed in the literature are rule-based and optimization-based techniques. Further deterministic and fuzzy-based approaches are the subcategories of rule-based techniques. The various control strategies are depicted in Figure 1.6. Most of the vehicle manufacturers are looking for easy and simply energy sharing techniques. There was numerous research articles presented with different EMCSs [24].

Thermostat or 'ON/OFF' strategy depends on the state of charge (SOC) of ESS [25]. A scheme with two levels of power management: i. long term with rule based control (RBC) and ii. Short term with meta-heuristic method was implemented by Travao et al.[26]. Gokce et al. proposed an RBC control to split the power among ESS. Based on the operating mode of the vehicle, the weighing factor is calculated. Based on the weighting factor the amount of power from the ESS is decided by the rule table. The author's proposed strategy can guarantee a reduction of 25% of discharge current and 50% of charge current [27].

A fuzzy based supervisory algorithm was introduced by Ferreira et al. It can efficiently regulate peak and average power demands from ESS [28]. Garcia et al. considered basic, cascade, equivalent consumption minimization, fuzzy logic and model predictive controls in their work and concluded equivalent consumption minimization control offers a better solution for heavy powered vehicle [29].

IV. CONCLUSION

In India, the demand for Oil resources is growing at a faster rate than in other countries. At the end of 2040, the expected demand for oil resources is 9.8 million barrels per day. Vehicle transportation accounts for 65% of the growth in demand. A total of 260 million automobiles, 185 million two- and three-wheelers, and 30 million trucks are expected to be on the road. Greenhouse gas emissions are a major issue in today's climate change debate, though. The United Nations has resolved that by 2050, at least half of the greenhouse gas emissions that were released in 2000 must be reduced. Since traditional internal combustion engines (IC) use more oil and contribute to climate change, the automotive industry is looking for an alternative. The best approach is to use electric cars (EVs) which emit no pollutants. However, despite recent improvements in battery technology, the initial and running expenses, time for recharging and the limited range of electric vehicles remain important issues.

REFERENCES

1. S. Alshahrani, M. Khalid and M. Almuahini., "Electric Vehicles Beyond Energy Storage and Modern Power Networks: Challenges and Applications," in *IEEE Access*, 7, pp. 99031-99064, 2019.
2. D. Block, J. Harrison, P. Brooker, "Electric Vehicle Sales for 2014 and Future Projections," *Electric Vehicle Transportation Center*, pp.1-12, 2015.
3. A. Khaliah and Z. Li, "Battery, Ultracapacitor, Fuel Cell, and Hybrid Energy Storage Systems for Electric, Hybrid Electric, Fuel Cell, and Plug-In Hybrid Electric Vehicles: State of the Art," *IEEE Transactions on Vehicular Technology*, 59(6), pp. 2806–2814, 2010.

4. D. S. Gautam, F. Musavi, M. Edington, W. Eberle and W. G. Dunford, "An Automotive Onboard 3.3-kW Battery Charger for PHEV Application," *IEEE Transactions on Vehicular Technology*, 61(8), pp. 3466-3474, 2012.
5. S. G. Chalk and J. F. Miller, "Key Challenges and Recent Progress in Batteries, Fuel Cells, and Hydrogen Storage for Clean Energy Systems," *Journal of Power Sources*, 159(1), pp. 73-80, 2006.
6. J. M. Miller, T. Bohn, T. J. Dougherty and U. Deshpande, "Why Hybridization of Energy Storage is Essential for Future Hybrid, Plug-In and Battery Electric Vehicles," *IEEE Energy Conversion Congress and Exposition*, pp.229-234, 2009.
7. A. W. Steinecker, T. Stuart and C. Ashtiani, "A Combined Ultracapacitor- Lead Acid Battery Storage System for Mild Hybrid Electric Vehicles," *IEEE Vehicle Power and Propulsion Conference*, pp.350-355, 2005.
8. Lalit Kumar, Shailendra Jain, "Electric Propulsion System for Electric Vehicular Technology: a Review," *Renewable and Sustainable Energy Reviews*, 29, pp. 924-940, 2014.
9. X. Lu, Y. Chen, M. Fu and H. Wang., "Multi-Objective Optimization-Based Real-Time Control Strategy for Battery/Ultracapacitor Hybrid Energy Management Systems," in *IEEE Access*, 7, pp. 11640-11650, 2019.
10. V. Boieca, "Energy Storage Technologies: The Past and the Present," *Proceedings of the IEEE*, 102(11), pp. 1777-1794, 2014.
11. Álvaro Cunha, Jorge Martins, Nuno Rodrigues and F. P. Brito, "Vanadium Redox Flow Batteries: A Technology Review," *International Journal of Energy Research*, 39(7), pp. 889-918, 2015.
12. Zhao P, Zhang H, Zhou H, Yi B., "Nickel Foam and Carbon Felt Applications for Sodium Polysulfide/Bromine Redox Flow Battery Electrodes," *Electrochim Acta*, 51, pp. 1091-8, 2005.
13. A. Burke and M. Miller, "The Power Capability of Ultracapacitors and Lithium Batteries for Electric and Hybrid Vehicle Applications," *Journal of Power Sources*, 196(1), pp. 514-522, 2011.
14. Andrew Burke, "Ultracapacitor Technologies and Application in Hybrid and Electric Vehicles," *International Journal of Energy Research*, 34(2), pp. 133- 151, 2010.
15. Khwaja M. Rahman, Mehrdad Ehsani., "Performance Analysis of Electric Motor Drives for Electric and Hybrid Electric Vehicle Applications," *Power Electronics in Transportation*, pp. 49-56, 1996.
16. Saqib Rind, Yaxing Ren, Lin Jiang., "Traction Motors and Speed Estimation Techniques for Sensorless Control of Electric Vehicles: A Review," *Power Engineering Conference (UPEC), 49th International Universities*, pp.1-6, 2014.
17. Johan Mdan, Maarten J. Kamper, "Performance of a Hybrid Electric Vehicle using Reluctance Synchronous Machine Technology," *IEEE Transactions on Industry Applications*, 37(5), pp. 1319 - 132 4, 2001.
18. M. Takeno, A. Chiba, N. Hoshi, S. Ogasawara, M. Takemoto, M. Rahman, "Test Results and Torque Improvement of the 50-kW Switched Reluctance Motor Designed for Hybrid Electric Vehicles," *Industry Applications on IEEE Transactions*, 48(4), pp. 1327 -1334, 2012.
19. Chan CC, Chau KT, "An Overview of Power Electronics in Electric Vehicles," *IEEE Transactions On Industrial Electronics*, 44(1), pp. 3-13, 1997.
20. M. B. Camara, Hamid Gualous, Frederic Gustin, Alain Berthon, "Design and New Control of DC/DC Converters to Share Energy Between Supercapacitors and Batteries in Hybrid Vehicles," *IEEE Transactions on Vehicular Technology*, 57, pp. 2721-2735, 2008.
21. P. Pisu, G. Rizzoni, "A Comparative Study of Supervisory Control Strategies for Hybrid Electric Vehicles," *IEEE Transactions on Control Systems Technology*, 15(3), pp. 506-518, 2007.
22. G. J. Offer, D. Howey, M. Contestabile, R. Clague, N. P. Brandon, "Comparative Analysis of Battery Electric, Hydrogen Fuel Cell and Hybrid Vehicles in a Future Sustainable Road Transport System," *Energy Policy*, 38(1), pp. 24-29, 2010.
23. Zhang Shuo, Xiong Rui1, Zhou Xuan3, "Comparison of the Topologies for a Hybrid Energy-Storage System of Electric Vehicles via a Novel Optimization Method", *Science China Technological Sciences*, 58(7), pp. 1173-1185, 2015.
24. A. Geetha and C. Subramani., "A Comprehensive Review on Energy Management Strategies of Hybrid Energy Storage System for Electric Vehicles," *International Journal of Energy Research*, 41, pp. 1817 - 1834, 2017.
25. Gao, J. P., Zhu, M. G., Strangas, E. G., Sun, F. c., "Equivalent Fuel Consumption Optimal Control of a Series Hybrid Electric Vehicle," *Journal of Automotive Engineering*, 223, pp. 1003-1018, 2009.
26. Trovao, J. P., Pereirinha, P. G., Jorge, H. M. and Antunes, C. H., "A Multi- Level Energy Management System for Multisource Electric Vehicles - an Integrated Rule-based Meta-Heuristic Approach," *Applied Energy journal*, 105, pp. 304-318, 2013.
27. Gokce, K. and Ozdemir, A., "A Rule-Based Power Split Strategy for Battery/Ultracapacitor Energy Storage Systems in Hybrid Electric Vehicles," *International Journal of Electrochemical Science*, 11, pp. 1228-1246, 2016.
28. Ferreira, A. A., Pomilio, J. A., Spiazzi, G. and Silva, L., "Energy Management Fuzzy Logic Supervisory for Electric Vehicle Power Supplies System," *IEEE Transaction on Power Electronics*, 23, pp. 107 - 115, 2008.
29. Garcia, P., Torreglosa, J. P., Fernandez, L.M. and Jurado, F., "Control Strategies for High-Power Electric Vehicles Powered by Hydrogen Fuel Cell, Battery and Supercapacitor," *Expert System with Application journal*, 40, pp. 4791-4804, 2013.
30. Mario, A., Hugo, N., Trovao, P., Paulo, G. and Humberto, M., "An Integrated Fuzzy Logic Energy Management for a Dual-Source Electric Vehicle," *IEEE 39th annual conference on Industrial Electronics Society (IECON), Vienna, Austria*, pp. 4564-4569, 2013.
31. He, Y., Zhou, W., Li, M., Ma, C. and Zhao, C., "An Adaptive Fuzzy Logic-based Energy Management Strategy on Battery/Ultracapacitor Hybrid Electric Vehicles," *IEEE Transactions on Transportation Electrification*, 2, pp. 300-311, 2016.
32. Vinot E, Trigui R., "Optical Energy Management of HEVS with Hybrid Storage System," *Energy Conversion And Management*, 76, pp. 437-452, 2013.
33. Agustin, M., Wenzhong, G. and Jesus, F., "Fuzzy Logic Energy Management Strategy for Fuel Cell/Ultracapacitor/Battery Hybrid Vehicle with Multiple-Input DC/DC Converter," *IEEE International Conference on Vehicle Power and Propulsion, Dearborn*, pp. 199-206, 2009.