

# Conceptual design of Hybrid Electric Aircraft

<sup>1</sup>Manjunatha Prabhu P, <sup>2</sup>Tejaswini R, <sup>3</sup>Ranjitha G, <sup>4</sup>Mythri L, <sup>5</sup>Chaithra Y H

<sup>1</sup>Assistant professor, <sup>2,3,4,5</sup>Students  
Electrical and Electronics Engineering  
P.E.S. Institute of Technology and Management, Shivamogga, India

**Abstract:** The goal of the conceptual step in database layout in this proposed system is to describe information linked to the software's internals in a clear and concise manner. The present artwork focuses on establishing a well-known approach for designing an all-electric and hybrid-electric plane from a conceptual standpoint, as well as simulating their flight profile to measure power intake for the highest possible accuracy. Hybrid electric and fully electric planes look to be one viable option for meeting lofty density emission and noise reduction requirements. Through the declaration of major performance increases, the Strategies Research and Innovation Agenda and NASA N+3 ambitions have established new demanding conditions for the aviation network. The design of a novel integrated power-energy gadget is one of the most promising factors, as evidenced by the growing interest in hybrid strength and universally electric-powered aircraft. The primary goal of the density hybrid-electric plane project is to increase the active efficiencies. To test hybrid propulsion operation tactics, Traditional fuelling generators and battery-powered hybrid electric aircraft (HEA) are used to power regional hybrid electric aircraft (HEA). An electric vehicle is being researched. This is where the battery fits into environmentally friendly principles. If multiple targets are optimised simultaneously, In just one optimization cycle, the hybrid propulsion device's capability can be thoroughly assessed.

**Keywords:** *hybrid electric aircraft, Regional hybrid electric aircraft, NASA N+3*

## Introduction

NASA is working with Boeing to explore a wide range of innovative propulsion technologies. Distributed propulsion and its aerodynamic implications in the LEAP tech project[1]. The feasibility of applying an electric propulsion system to a transport aircraft will be determined by the storage device's energy and power capacity, the development of key component performance characteristics such as gravimetric specific power and efficiency, and the electrical components' scalability potential[2,3]. The majority of the studies does not send a clear message to lawmakers and aircraft manufacturers concerning hybrid electric aircraft's Profitability and environmental friendliness are two important factors to consider. are two of the most important factors to consider (HEA). A lack of research into the role of the two primary battery performance indicators, power and energy density, as well as an operation plan based on a specific target setting, is cited as a major research gap. The Hybrid Electric Propulsion System (HEPS), a growing propulsion technology, comes to mind for the researchers and sparks a lot of interest. To produce propulsion, HEPS combines an electric power train with a traditional combustion engine. It has the ability to combine the clean power of an electric propulsion system with the expanded range of an internal combustion engine. Two or more power sources with various configurations are integrated in a hybrid propulsion system to increase overall performance.

A hybrid electric aircraft is one that uses a combination of lithium-ion batteries and aviation gasoline. When compared to pure electric aircraft, the hybrid electric power train can effectively extend flight range. By May 2018, over 30 hybrid electric aircraft projects had been announced, with short-haul hybrid-electric airlines expected to launch in 2032. The aerospace industry is currently experiencing a non-traditional market pull-technology push innovation dilemma. [5]. When compared to an ICE-powered aircraft, the electric aircraft has a higher level of stealth. The market pull arises as a result of society's need for greener, more efficient, and on-demand transportation, which is supported by policymakers' and regulators' goals and actions.

The study begins with a brief explanation of the notion of a conceptual hybrid electric aircraft as well as a qualitative evaluation. The structure of this document is as follows: The first section examines policymakers' and regulators' actions and visions. Improve the energy and power capacity of the storage device in Section 2. The conventional combustion engine is integrated into section 3 to supply the propulsion system.

## 2. Hybrid electric propulsion fundamental

This section gives an overview of Aircraft propulsion and hybrid technologies at the moment. An OAD simulation requires a propulsion operating plan, which has been expounded. Profile of merit are used to examine the effects of implementing hybrid electric propulsion in aeroplanes.

### 2.1. Propulsion Architecture

Hybridization of the impulse system allows for the development of new Technologies for propulsion that increase aerodynamics even further The concept of distributed propulsion [with more than ten propulsions] is an extreme example. The wing's aerodynamic lift properties may be improved by the revised propulsion arrangement. Two electric-driven wingtip propellers, as well as a gas turbine-powered propeller on each wing are a version of this design. DLR and NASA propose a wingtip propeller architecture that promises greater aircraft lift while reducing weight and cost. A larger number of engines can result in lower over sizing elements affecting each propulsion's power rating since one engine remains dormant.

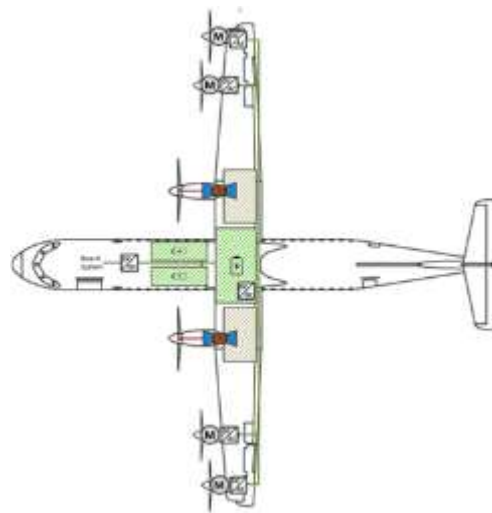

Figure 1. ATR-72 wingtip propeller architecture schematic.

The upright tail is also utilised to guide the motion in the OEI. The V-Tail must handle fewer momentums When the engines are synchronized and differential thrust is employed, resulting in a mini size. These advantages are expected to be realised with the advent of new propulsion technologies. Due to rising maintenance costs, several gas turbine topologies result in greater prices. More than two electric engines in a single architecture does not require a large cost penalty because electric propulsion is predicted to reduce maintenance efforts.

**2.2 Power train configuration**

A hybrid propulsion system combines two or more power sources in various layout to boost overall performance. This research only looks at two methods of energy storage: fuel and batteries. The most common fuel/battery hybridization system architectures are series, parallel, and series-parallel architectures.

**2.2.1 Series configuration**

In a series hybrid system, the propeller is only driven by the electric motor. 16A The combustion-derived power of the engine is converted into electrical power by a generator. The electrical energy can be used to power the EM directly or stored in the battery via a charging process. The series hybrid electric system is the most easily adapted to distribute electric power train. As a result, it is now widely accepted as a viable alternative propulsion technology for integrating multi-rotor aircraft with large-scale planes. In series hybrid systems, the engine is completely separate from the propeller, and its product power is unrelated to the power requirements of the power train. In other words, the engine may function at its best under a range of circumstances. While the engine's lifespan is extended, its fuel economy can be maintained. Furthermore, the series architecture gives a particular benefit in terms of position freedom for the ICE-generator set due to mechanical decoupling. Due to significant power losses in the combustion and electrical energy conversion processes, the series design has a low system efficiency. It also requires three different types of propulsion: an engine, a generator, and an electromagnetic motor. If the series HEPS is designed for sustained climbs, all three propulsion devices must be sized to handle maximum power. As a result, HEPS are both expensive and huge when used in series. Finally, series architecture is unable to utilize the engine and motor's combined maximum power potential because the engine and the load are not physically connected.

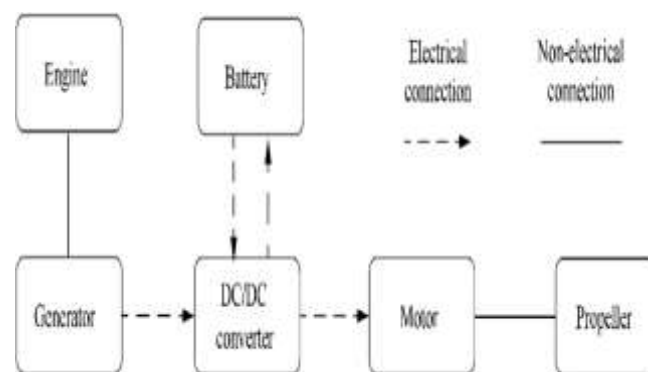

Fig 2: Series configuration.

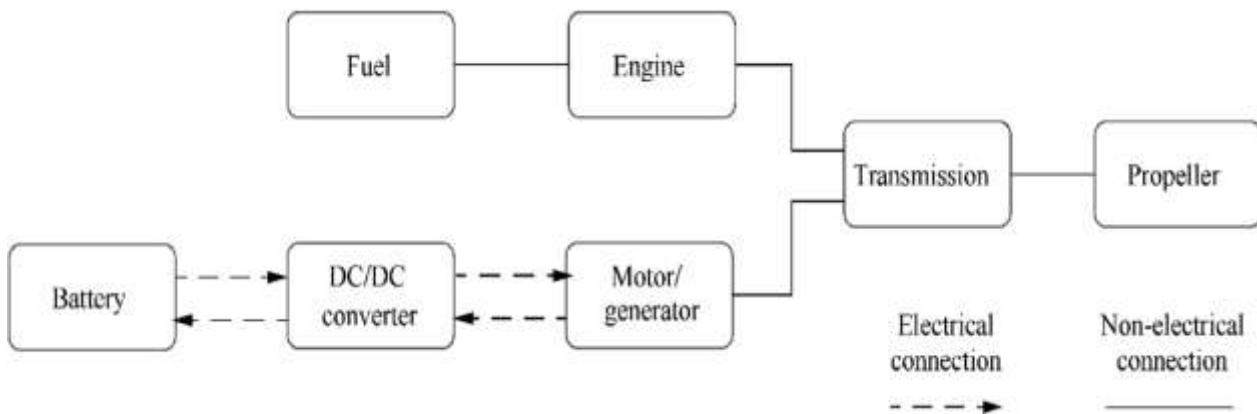

Fig 3: Double-shaft parallel configuration.

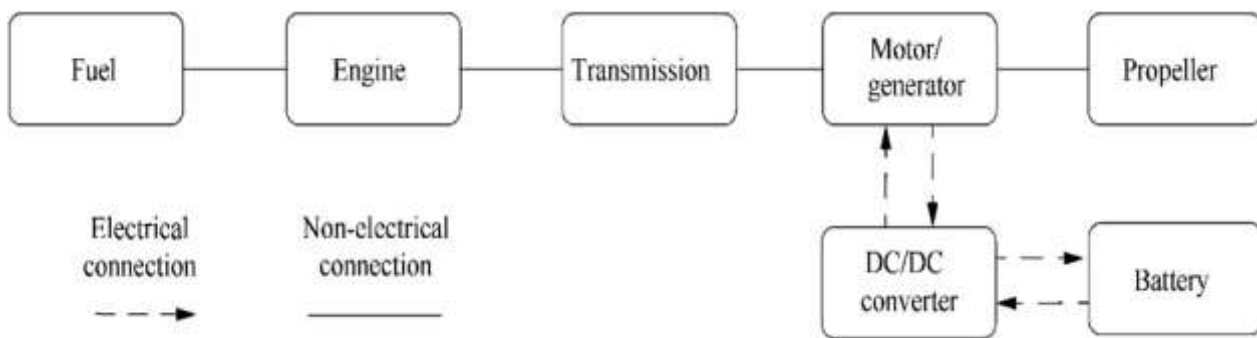

Fig 4: Series-parallel configuration.

**2.2.2 Parallel configuration**

A smaller engine and an electric motor can also be used to achieve the same results. Only the engine's maximum continuous power must be verified. for long-climb trips. In comparison to the series configuration, power losses are reduced, and there is no requirement for the conversion of mechanical to electrical energy. However, because the rotational speed of the propeller is not always the same as the engine's ideal speed, operation in the engine's optimum region cannot be assured. There are two techniques of dealing with this problem in general. The first and most straightforward option is to install a Continuously Variable Transmission (CVT), which allows the engine and propeller rotational speeds to be independent. The second option, which is more cost-effective, is to design an energy management strategy.

The energy management method can optimize the engine's and motor's power contributions, allowing the propulsion devices to perform at their best. Parallel hybrids are further categorised based on where the motor/generator is located in the drive train. The two most common architectures for aeroplane applications are the double-shaft and single-shaft architectures. Parallel hybrids are further categorised based on where the motor/generator is located in the drive train. As shown in Fig. 3, On two distinct driving shafts, the engine and the motor/generator are installed.

The engine, motor, and generator can all have different speeds than the propeller and each other. The double-shaft parallel configuration is the name given to this system. Similarly, if a CVT is employed in this architecture, the speed of two propulsion devices can be separated from the speed of the propeller. Because the transmission only has one input shaft, the architecture is known as single-shaft if the engine is connected to the motor/generator but not directly to the propeller. In general, the propeller is directly connected to the electric machine, whereas the engine is connected to the electric machine via decoupling devices and gears. The speed of the motor/generators is always strictly related to that of the propeller in this configuration. This architecture is particularly well suited to the mid-scale hybrid aeroplane because of its lower mechanical complexity, which is important for reducing system weight and improving system safety.

**2.2.3. Configuration in series and parallel**

A mixture of the two concepts described above is the series-parallel architecture, often known as the power split architecture. Figure 4 shows how the propeller, engine, motor, and generator are all connected to a planetary gear. This design not only allows for additional power distribution flexibility, However, it also enables the engine and motor to run at their most efficient levels. The series-parallel configuration of the hybrid propulsion system is the most advanced; still it also needs the most complex clutch/gearing mechanism and energy management. The graphic above depicts the most common arrangements. One of them is the series setup, which allows the engine to perform at its optimum. Yet, the system's efficiency is low due to significant power losses during energy transformation. The series-parallel architecture is the most practical, but it's also the most challenging. Extreme

recommended design for aviation applications due to its substantial complexity. However, the system's efficiency is low due to significant power losses during energy conversion. The series-parallel architecture is the most practical, apart from it's also the most challenging. It is the least recommended design for aviation applications due to its substantial complexity.

### 2.3 Components of Propulsion's Scope

Components of propulsion and their characteristic values used in HEA modeling are introduced in this section. When choosing propulsion components, the density in kg, or component weight, is the most important thing to consider. Additional mass that must It takes more energy to be carried in flight. to carry because an increased maximum takeoff weight (MTOW) needs a greater order for propulsion to drive the aircraft.

- Conventional Propulsion Components
- Electric Propulsion Components

#### 2.3.1 Conventional Propulsion Components

Jet fuel is used to propel larger aircraft in the traditional sense. They have a very high energy density of 11.9 kWh/kg ,but 11.9 kWh/kg, which is a lower heating value. As the kerosene is burned, the fuel mass decreases with the mission time. Mechanical energy is created by converting chemical energy into mechanical energy. This method has a relatively poor efficiency of around 40%, which drops even further for lower turbine power ratings. To create thrust, a ducted or unducted fan is installed on the main shaft of the gas turbine. The thrust technology chosen is determined by the cruise speed. For lesser speeds, unducted propellers are more efficient than ducted fans. Mach 0.44 has been chosen as the cruise speed for the regional reference aircraft. which is slower than short-haul jets' cruising speeds of Mach > 0.76. As a result, the reference aircraft's propellers are unducted.

#### 2.3.2 Electric Propulsion Components

The electric motor is a form of electric-powered propulsion system. A power management and distribution (PMAD) system is a system that manages and distributes power. consisting of inverters, converters, and cables, is necessary to assure safe motor running while controlling voltage and current levels. For weight-constrained applications, electric motors with 2–10 kW/kg gravimetric power densities are unusual. The PMAD's weight is taken into account. The best power-to-weight ratios and power densities up to 40 kW/kg are found in high temperature superconducting (HTS) materials. are the focus of recent research. When conducting currents, these superconducting materials have essentially no resistive losses. HTS materials must be cryocooled to a temperature of 27–77 K to become superconducting.

HTS motors with cryogenic cooling have gravimetric power densities of 7–25 kW/kg. and efficiency of 95–99.5 percent are predicted by NASA, the BHL, and Masson et al. research. When compared to gas turbines, the efficiency of electric motors is less affected by the rated power output PMAD components must meet the rated voltage of the electric propulsion system as a design requirement. According to Vratny et al. and Jones et al., a system voltage of 3 kV (DC) provides the best efficiency for all electric needs, which is exactly what the simulation shows. Converters and inverters are used to handle voltage variations. In the year 2035, commercially available power electronics will have a value of 26 kW/kg. Efficiencies range from 98 to 99.5 percent.

### 3. Methods of Simulation

The simulation approaches, which comprise This document describes the aircraft's top-level requirements, propulsion parameters, and simulation structure part.

#### 3.1 Simulation Methods

The simulation approaches, which comprise This section covers the aircraft's top-level requirements, propulsion parameters, and simulation structure.

Basic input factors for the OAD simulation are design requirements. The given design mission is the primary input, and it influences the aircraft's performance. A full-payload regional flight is one of the aircraft's top-level requirements. 95 kilograms per PAX is chosen based on the reference aircraft's design. According to a NASA assessment of regional (900NM) air transportation demand in the United States in 2030, 85 % of all journeys will be under 350NM in length [13]. As a result, for this simulation, a design range of 350 NM (648 km) was used. This type of aircraft's design missions takes place at an altitude of FL250 and a speed of Mach 0.44. The takeoff field is 1200 metres long, while the landing field is 1060 meters long. In addition to the OEI situation, the simulation adds reserve mission safety rules, such as a 45-minute cruise at 1500 feet as a reserve and a minimum second climb gradient of 2.4 percent for twin-engine planes, and 3% for planes with four or more engines.

#### 3.2 Propulsion Parameters

Table 1 lists the framework utilized in the simulation. Subsystems like cooling are included in the The chosen technologies' gravimetric density and efficiency factors HTS technology is not used, which has the major benefit of incurring fewer losses. As a result, lower electric motor and PMAD efficiencies are chosen, which are comparable to current technology. These normally cooled systems are expected to have a power density alike to HTS modules. The earlier mentioned nickel-plated aluminum cable has already been removed. The maximum power delivered by each electric motor is used to calculate the current rating. The distance connecting the electric motors and the energy source is equal to the length of the wires.

Components	Gravimetric densities	Efficiencies
Electric motor	15 kW/kg	95%
Inverter/converter	20 kW/kg	98%
Electric cable	0.00324 kg/A/m <sup>1</sup>	98.5%
Battery 1 (low power Li-S)	0.65 kWh/kg 0.4 kW/kg	90%
Battery 2 (high power Li-S)	0.65 kWh/kg 1 kW/kg	90%
Battery 3 (similar to Li-Air)	1 kWh/kg 1 kW/kg	90%

Table 1: overview of electric propulsion components

### 3.3 Simulation Structure or frame work

A wide range of unique technology integrations can be enabled, in addition to the benefits of HEA, such as fewer in-flight emissions, lower noise, more effective energy conservation, and more reliable systems. HEA, for example, enables the efficient application of wing tip vortices without the need for additional equipment.

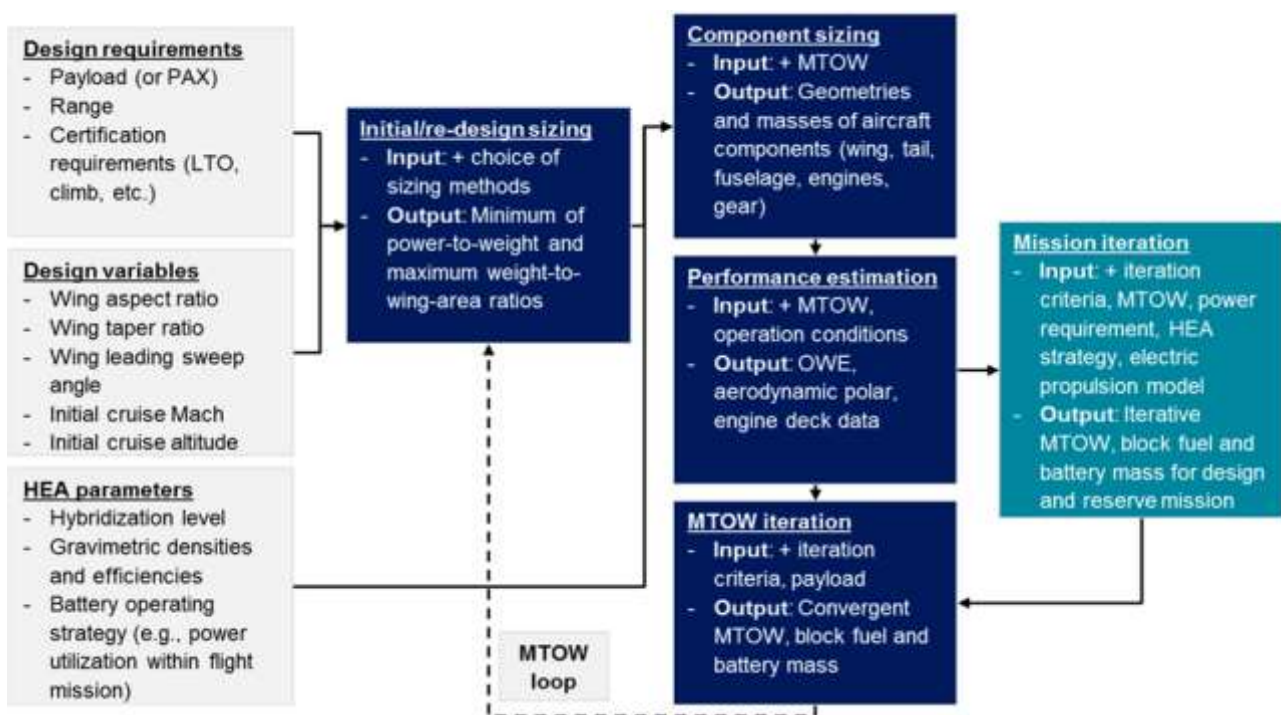

Fig 5: flow diagram of the general approach for modeling HEA

Fi

The core modeling technique is found on an aircraft design and optimization tool that takes into account the important flying phases of takeoff, climb, cruise, descent, and landing. The modeling method is explained in depth in. As a result, just a quick overview of the key features is provided in this contribution. Rather than giving a detailed description of the tool, it concentrates on the most important approaches established for current hybrid electric propulsion. Figure 5 depicts the modeling structure's general approach, which follows standard aircraft conceptual/preliminary design logic. To make the characteristics and modeling approaches more understandable, some key points are discussed below.

The performance of each propulsor can be harmed by over sizing them. Operational features such as flying altitude and speed can be specified as design variables or viewed as design parameters, similar to the multidisciplinary design optimization (MDO) technique for traditional aircraft design. The modeling approach includes propulsion parameters in addition to the HEA strategy parameters. During mission iterations, the HEA parameters are utilised to communicate Information about the components as well as the energy requirements. A modified approach for turbo-prop engines has been devised, similar to the methods for evaluating the performance of turbofan engines that were introduced in.

Engine performance is calculated using publicly accessible data from the FAA/EASA engine certification database and the ICAO engine emission database. How developed a number of empirical methods for determining available engine thrust at various flight speeds and altitudes, as well as specific fuel consumption dependent on speed and altitude? To provide a more realistic approximation of engine performance statistics, improvements are being made.

### 3.4 Energy Strategy for Batteries

The functioning battery's strategy can be changed. Figure 6 depicts a simplified mission profile for total system power. Each phase of the flight is depicted with a constant power setting, such as takeoff, climb, and cruise. There are likely to be two extreme strategy possibilities.

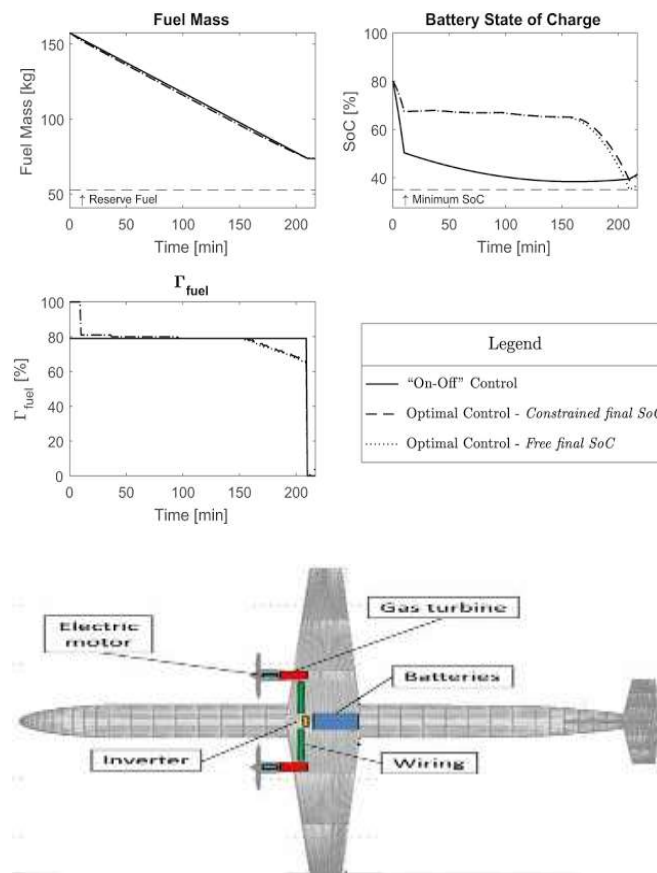

Fig 6: Battery energy strategy

### 4 Hybrid electric powered aircraft

The widespread study and advancements in hybrid electric propulsion systems in autos might be used to aviation. When compared to electric cars, automotive hybrid systems provide enhanced endurance time, as well as Noise, pollution, and fuel consumption are all decreased, which is impossible with gasoline-powered vehicles. Following the recognition of those profits, aeronautical academia and industry began to use HEPS to power aeroplanes. There has been a lot of interest in further research into this technology and its applicability to small to large-scale aircraft.

#### 4.1 Small-scale hybrid aircraft

Scholars first examining and demonstrating the possibility of hybrid electric technology in the small-scale sector Unmanned Aerial Vehicle (UAV). Harmon and colleagues at the University of California-Davis began researching small hybrid unmanned aircraft for ISR in 2005. (Intelligence, Surveillance, and Reconnaissance). Harmon et al. proposed scaling the aircraft wing and hybrid propulsion system components at the same time using a concept design process. The scaling process resulted in a 13.6 kg hybrid UAV with a 4.65 m wingspan and 220 Wh batteries. Neural network control was used to optimise the energy distribution of the hybrid UAV and propulsion system. According to simulations, the anticipated hybrid electric UAV would use 54% less energy for a three-hour ISR flight than a gasoline-powered UAV. Harmon attended the Air Force Institute of Technology to further his schooling (AFIT). Hiserote and he put a number of battery installations and charging programmes to the test. The clutch-start parallel arrangement, in combination with the battery charge-sustaining technique, was shown to be the optimal design for a small unmanned aircraft with the smallest empty weight. To continue the design, Ausserer and Molesworth constructed and integrated a hybrid electric system into a remotely piloted unmanned aerial vehicle The Honda GX35 engine (969 W) and Fuji motor (1.2 kW) were chosen based on Hiserote's optimal sizing.

Ground integration had partially confirmed the earlier conceptual design, but the flying test had not yet been completed. A parallel HEPS test setup was developed by the Queensland University of Technology (QUT) research team, which includes a 10 cc combustion engine and a 600 W brushless motor. To save gasoline, Hung and Gonzalez developed an Ideal Operating Line (IOL) control approach. Numerical simulations showed that, compared to a non-hybrid system, aircraft performance might be significantly enhanced, and fuel consumption could be reduced by 6% with just a 5% weight penalty.

#### 4.2 Mid-scale hybrid aircraft

HEPS Mid-scale aircraft research (general aviation planes or other light planes) has also gotten a lot of attention. As previously reported, AFIT researchers investigated the possibility of installing HEPS in unmanned aircraft.

##### HEPS technology

According to the studies, is a viable trade-off solution for small-scale aircraft that reduces pollution and fuel consumption while preserving adequate range and endurance. On the other side, Hiserote questioned whether hybrid propulsion could be used on larger planes. Another AFIT graduate student, Ripple, explored the possibility of HEPS for mid-scale aircraft by retrofitting the DA, Cessna 172 Skyhawk, and Predator. The modified hybrid Cessna 172's MTOW was nearly identical to the original Cessna's. Although the projected mild HEPS might save up to 54 kilograms of fuel, the payload was reduced by 27 kilogram's.

For an 8-passenger skydiving plane, Glasscock et al. developed a parallel hybrid propulsion system. The impact of different hybridization ratios on fuel consumption and climb rate was studied. One 224 kW turbine engine and two 224 kW electric motors were built after a constant hybridization ratio of 0.67 was chosen. According to the findings, the effective flight time was drastically reduced at this ratio. As a result, short-duration high-power missions, such as skydiving, may benefit more from hybrid propulsion technology than standard long-duration missions.

A Piper PA-38 Tomahawk with a 22.6 kW EM and a 54.5 kW ICE was converted by Boggero et al. The empty mass of the reference Piper aeroplane was lowered from 512 kg to 466 kg when the HEPS hybridization was set at 30%. Because the smaller ICE could operate in a more efficient working area, the fuel load could be lowered by roughly 10 kg. The series and parallel designs of HEPS for general light aircraft were researched by Finger et al. In terms of minimising global weight and on-board fuel weight, the parallel hybrid architecture is preferred over the series hybrid design, according to the analysis. In a later study, Finger et al. considered the engine failure emergency. The authors realised that the first ideal design was not available due to new engine failure constraints. In addition, if a 100-kilometer diversion was requested due to an engine failure, the MTOW of the same hybrid aircraft would be significantly increased (by 50 percent).

#### 4.3 Large-scale hybrid aircraft

The Delft University of Technology completed a series of studies on the use of HEPS to regional jets. Bogaert investigated the possibility of hybrid electric regional aircraft saving fuel and lowering pollution. The hybrid regional aircraft is based on the ATR 72-600, a 68-passenger aircraft. The wing area of the reference and hybrid aircraft differed by 18%, which was the most significant airframe difference. Following that, the fuel consumption of hybrid aircraft was researched, and it was discovered to be strongly dependent on flight range. As a result, Voskuijl and Bogaert et al. developed a new analytical range equation to predict the ranges of hybrid airliners. According to the findings, the parallel hybrid-electric architecture produced a 28 percent reduction in fuel mass at the cost of a 14 percent increase in MTOW. It's worth noting that the outcomes were achieved thanks to advancements in a variety of electric and aerospace technologies.

Under various technological assumptions, Zamboni et al. studied the fuel-saving possibilities of three hybrid configurations. The findings revealed that, given today's state-of-the-art technology, a parallel design is a conservative option, but series architecture can benefit the most from technological improvements. Vries and Hoogreef et al. explored the hybrid electric system's aero-propulsive benefits, such as leading edge and boundary layer ingestion. These revenues will be easily offset by the expanding masses unless better technologies can considerably lower the powertrain mass. Pornet et al. (from Bauhaus Luftfahrt) completed the sizing and evaluation of a parallel hybrid electric system for a 180-passenger reference airliner, which consisted of On the output shafts of traditional gas turbines, motors are installed.





Aircraft	Institute or corporation	Hybrid configuration	MTOW	Maximum Payload	Flight time
	Air Force Institute of Technology	Parallel	16 Kg	1.2Kg	Unknown
	Quaternium	Series	20 Kg	6Kg	2H
	Top Flight Tech	Series	50 Kg	10Kg	1H
	Year	Parallel	>10 Kg	5Kg	1H

Table 3: Summary of small-scale hybrid aircraft.





Aircraft	Name	Institute or corporation	Hybrid configuration	MTOW	ICE/EM installed power
	SOUL	University of Cambridge	Parallel	210 Kg	8/12Kw
	DA36 E-Star	EADS, Diamond Aircraft and Siemens	Series	770 Kg	30/70Kw
	EEL	Ampaire	Parallel	2100 Kg	156/180Kw
	Surefly	Workhorse	Series	680Kg	150/-Kw
	EVTOL	Rolls-Royce	Series/parallel	Unknown	500/-Kw

Table 4: Summary of large-scale hybrid aircraft







Aircraft	Name	Institute or corporation	Hybrid configuration	MTOW	Seats	ICE/EM installed power
	-	Delft University of Technology	Parallel	22t	68	2.2/1.2MW
	E-Fan X	Airbus, Rolls-Royce, Siemens	Series	Unknown	Around 100	3*31kN/2 MW
	ZA10	Zunum	Series	5 t	12	1MW/-
	ECO-150	ESAero	TeDP	63t	100	-/18MW
	N3-X	NASA	TeDP	223t	300	60/56MW

Table 4: Summary of large-scale hybrid aircraft

## 5. Conclusions

The current state design and energy management of hybrid electric propulsion systems, as well as varied scales of hybrid electric propelled aircraft, was investigated in this paper. According to the paper, the study of mid-scale hybrid aeroplanes can provide the most to both research and practice. Small-scale hybrid aircraft have been thoroughly researched and tested, but large hybrid aircraft will remain in the concept stage unless electrical storage technologies improve. Multi-objective optimization has various advantages over single-objective optimization and non-optimization-based techniques, as discussed in the overview of design processes. In order to manage energy distribution, both non-causal and causal control should be researched, with a focus on SoC regulating systems that maintain aircraft safety. Overall, there are few works that cover the conceptual design and energy management of hybrid aircraft using multi-objective optimization, convex programming, and fuzzy based ECMS.

The outcomes of the literature review guided our initial study activity, which is briefly reported in the paper. In terms of Multi-objective optimization is the best for conceptual design, but it has a high processing complexity. To lower the computational cost of multi-objective optimization, the novel BNDS algorithm was introduced. In the field of non-causal energy management, a convexification method was recently proposed. To address the fact that most energy management systems do not consider vehicle safety if the engine fails, a fuzzy optimization was included to ECMS, filling a research need. The battery's role in hybrid electric propulsion systems, as well as its crash on the aircraft's environmentally safe, are discussed in this article. According to the results of HEA design modeling in the aviation environment, battery performance and, as a result, weight are the most important variables in establishing HEA's technological feasibility. The proposed propulsion strategy can be used by an aircraft designer to improve future HEA models. The distinction between the battery's power-to-energy ratio and its gravimetric density must be understood. These should be adjusted to the aircraft's mission profile and operation plan. Each OAD must adopt an ideal propulsion plan to achieve maximum battery energy extraction. To make hybrid electric propulsion for planes viable, battery development Materials that are lighter and endure longer should be prioritized.

## REFERENCE

1. Stoll, A.M.; Bevirt, J.; Moore, M.D.; Fredericks, W.J.; Borer, N.K. Drag Reduction Through Distributed Electric propulsion. In Proceedings of the 14<sup>th</sup> IAA Aviation Technology, Integration, and operations Conference, Atlanta, GA, USA, 16-20 June 2014; pp. 1-10
2. K. Sivasubramaniam, T. Zhang, M. lokhandwalla, E. T.Laskaries, J.W.Bray, B.Gerstler, M.R.Shah, and J P Alexander. Development of a High Speed HTS Generator for Airborne Applications. IEEE Transaction on applied superconductivity, 19(3):1656-1661, 2009. doi:10.1109/TASC.2009.2017758.
3. Gerald V Brown. Weights and Efficiencies of Electric Components of a Turboelectric Aircraft Propulsion System. In 49<sup>th</sup> AIAA Aerospace Sciences Meeting including the New Horizons Forum and Aerospace Exposition, Orlando, Florida, 2011. Doi:2011-225.

4. Philippe JMasson and Cesar A Luongo. HTS Machines for Application in All-Electric Aircraft. In proceeding of the PES Meeting, Tampa, Florida, 2011. doi:2011-225.
5. Committee on propulsion and energy systems to reduce commercial aviation carbon emission. Commercial aircraft propulsion and energy system research, Washington, D.C.; National Academics Press;2016
6. Federal Aviation Administration (FAA). Part 25—Airworthiness Standards: Transport Category Airplanes Subpart B. 2017. Available online: [https://www.ecfr.gov/cgi-bin/text-idx?SID=caefbbc53bccf4e355983e23e3c168a6&mc=true&node=se14.1.25\\_1121&rgn=div8](https://www.ecfr.gov/cgi-bin/text-idx?SID=caefbbc53bccf4e355983e23e3c168a6&mc=true&node=se14.1.25_1121&rgn=div8) (accessed on 28 August 2017).
7. Gammeter, C.; Krismer, F.; Kolar, J.W. Weight and efficiency analysis of switched circuit topologies for modular power electronics in MEA. In Proceedings of the IECON 2016—42nd Annual Conference of the IEEE Industrial Electronics Society, Florence, Italy, 23–26 October 2016; pp. 3640–3647.
8. Kraytsberg, A.; Ein-Eli, Y. Review on Li-air batteries—Opportunities, limitations and perspective. J. Power Sources 2011, 196, 886–893. [CrossRef]

#### **Abbreviations**

ATM	Air traffic management
DOC	Direct operating costs
DoH	Degree of hybridization
FEA	Full electric aircraft
HEA	Hybrid electric aircraft
HTS	High-temperature superconducting
LTO	Landing and takeoff
MDO	Multidisciplinary design optimization
MTOW	Maximum takeoff weight
OAD	Overall aircraft design
OEI	One engine inoperative
OWE	Operating weight empty
P/E-ratio	Power-to-energy-ratio
PSFC	Power specific fuel consumption
RTP	Regional turboprop
P/E-ratio	Power-to-energy-ratio
PMAD	Power management and distribution
SOC	State of charge