

# SMART MINING SYSTEM USING ATMEGA328 MICRO CONTROLLER

Akanksha Gosavi<sup>1</sup>, Megha Jadhav<sup>2</sup>, Priyanka Navle<sup>3</sup>

Department of Electronics and telecommunication  
Sir Visveswaraya Institute of Technology Chincholi Nashik.

**Abstract:** The accidents in mines are increased day by day. There are numerous life losses of many skilled workers and laborers. There is no advent precaution measure to detect the alarming cause of the mine accidents and provide an alert system. Occupational accidents and occupational diseases are common in the mining. The most common causes of accidents in mining are firedamp and dust explosions, landslips, mine fires, and technical failures related to transport and mechanization. An analysis of occupational accidents in the consideration of social and economic factors reports that the real causes behind these accidents, which are said to happen inevitably due to technical deficiencies or failures. Thus an automated alarming mine accident detect ion system is employed to rescue and protect the workers from the hazards. This system incorporates the combined action of the temperature, pressure and gas sensor and IOT module to detect the temperature, pressure and atmosphere in the mine and log every data onto the cloud using data logging. Then these data are accepted by a admin controlled sever page through data acquisition. The data processing takes place at a server page and the alert is send to the device to glow the alarm and to the concerned officials and rescue stations for taking the prevention measures. **Keywords:** Node MCU, Temperature Sensor, IOT Module, Cloud, Data Logging, Accident.

## INTRODUCTION

Today, mining is the process of extracting coal from the ground. The natural conditions of coal mines are highly complicated, and mining conditions are extremely capricious. The structure of a coal mine environment is complex; the space for branch tunnels is limited, and the directions of branch tunnels are not fixed. Wired transmission systems are often installed only in the main tunnel, which substantially limits the expansion of the network. When underground mining advances continuously, no wired network can be established in real time; naturally, it is thus impossible to monitor these dangerous regions in real time. In addition, due to cost and maintenance limitations, no safety monitoring systems are installed in abandoned underground tunnels, creating a great potential safety hazard. Many disasters can occur in mines, which increases the insecurity of coal mining and easily leads to major accidents, causing extreme difficulty in establishing safety. Thus, for coal mine safety monitoring and control, there are still many shortcomings in wired monitoring and control that should be addressed. It is not easy to install wired coal mine safety monitoring and control systems in many coal mine regions, such as abandoned tunnels and mining sections. Our project is coal mine monitoring system and alert system using IOT. It can detect all the hazardous gas using gas sensors, dust sensor, temperature and humidity sensor in the coal mine. Buzzer will glow after the threshold value of the gas. Hence this project will be use as rescued system and precautions for the coal mine workers.



Figure 1.1: Mining

The accident is any uncertain activity due to unavoidable circumstances and carelessness of some people. This incident is happening continuously all around the world. A large number of workers (approximately 2.3 million) die each year worldwide, 350,000 because of occupational accidents and approximately 2 million because of occupational diseases. Occupational health is defined as an area of application in which the effects of work life on health are investigated. A public health approach, using the notion of occupational health represents a partial understanding of health, leads to defining workplace and work life as outside of public health. The reasons for that are that citizens are seen not as workers but as consumers and that work life is moved out of the healthcare field. This causes occupational health to detach from public health when organizing healthcare services. The basic area that problems arise in terms of worker's health and safety is the production activities phase. Production activities consist of main activities such as excavation, ground support, and haulage as well as activities such as electricity maintenance, establishing and managing pressurized room networks, communication and signalization systems, and maintenance and repair of various machines

and equipment. In particular, accidents in coal mining related to collapses, pit fires, firedamp and coal dust explosions, haulage, and mechanization frequently occur in underground pits. Thus they end up with many complications physically.

### PURPOSE

Mining has been a very dangerous activity. The principal hazards are mine wall failures and vehicle collisions; underground mining hazards include suffocation, gas poisoning, roof collapse and gas explosions. Chronic lung diseases, such as pneumoconiosis (black lung) were once common in miners, leading to reduced life expectancy. In some mining countries black lung is still common. However, in lesser developed countries and some developing countries, many miners continue to die annually, either through direct accidents in coal mines or through adverse health consequences from working under poor conditions.

### EXISTING SYSTEM:

In allusion to the efficiency problem of the actual association rules mining algorithms in the process of disposing massive data, an improved one LRE based on one-dimensional linked list is put forward in this paper. And these tests show that LRE takes priority of apriori and FP-growth algorithms in implement efficiency. To resolve the large number of alerts and the high false positive rate issues, it constructs an intrusion alerts analysis system model (IAAS) with LRE applied. Finally, the validity in the aspect of reducing the number of alerts and the false positive rate has been showed by the experiments

The paper is an attempt of applying EDM methods on Moodle data in order to detect specific behaviours within student groups with the tendency to fail the course. The research is conducted on Moodle logs gathered in the blended course Programming 1. Extracting and using crucial information on time can be a turning point for students in at-risk stage, which is what we tried to achieve in this research

Impact of Gas Control Policy on the Gas Accidents in Coal Mine<sup>2</sup>- Coal plays an important role in the supply of energy worldwide for producing heat, electricity and other valuable industrial materials over the past few centuries. To date, coal still represent approximately 27.7 of the total primary energy supply in the world [4] According to statistics, in 2018, the total coal consumption in the world was 3.772 billion tons of oil equivalent. Among them, the United States used 317 million tons, and India used 452 million tons. China ranked first in all countries with 1.907 billion tons of coal consumption (BP, 2019). China is currently the world's largest consumer of coal, as well as the largest emitter of energy-related carbon dioxide (CO<sub>2</sub>). Nearly 80 are from the combustion of coal and coal derived products [4]. With the rapid development of China's economy, China has become a major energy producer and consumer in the world.

### SYSTEM ARCHITECTURE

Mine safety systems based on IoT seamlessly integrate gas sensing monitoring, miner tracking, and cloud computing to create an intelligent loop of safety through analytics. IoT utilizes BLE for transmitting data fromn Arduino modular sensors. The cloud is helpful for determining the service state of the mine and for sharing information. The coal mine fire monitoring system based on Zig-bee technology, and discusses the network data transmission process in the system. When the system is applied to an actual coal mine, it achieves a sound fire monitoring effect. The wireless sensor network (WSN) coal mine fire monitoring system consists of such three subsystems as data acquisition subsystem, control center subsystem and emergency response subsystem. With sensor nodes as the basic unit, the WSN is divided into five parts: sensor module, treatment module, wireless communication module, location module and power supply module Internet is different than IOT such away it transcends Internet connectivity by enabling every objects that utilizes embedded circuits to interact with each other utilizing the current Internet infrastructure Since the scope of IOT has grown by ever green tremendously as currently everything will be based on IOT at the end 2020 the technology will be reached at the top. With the advent of IOT the manufacture has great scope.

There are existing coal mine alert systems that is built using sensors and WSN. The coal mine intelligent monitoring system, through the mine field of ZigBee nodes to collect a variety of wireless data, through the switch to down hole monitoring sites which adopts a ring network connection that can communicate conveniently. In addition the system sets up a backup underground control and monitoring stations. The data is transmitted using Ethernet connection. It includes wireless data acquisition subsystem based on ZigBee network, industrial Ethernet transmission subsystem and remote monitoring system.

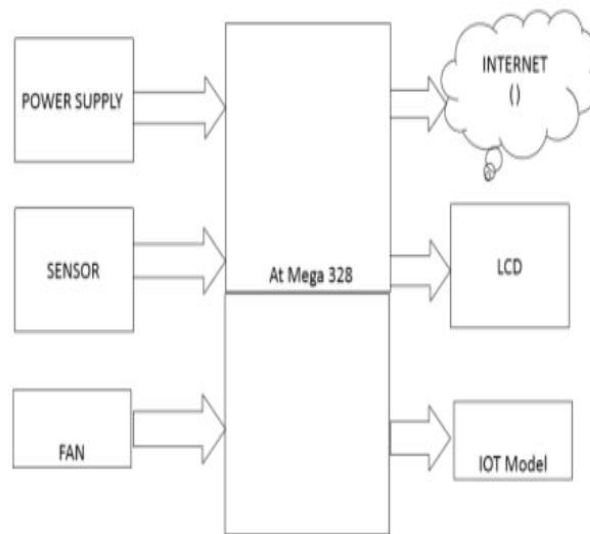

Figure 3.1: Block Diagram

### Fig -1: System Architecture Diagram

1. The designing process will start as per the waterflow model in which it will start from requirement gathering about how the project could be implemented and what could be the new thing which could be added to the concept
2. After this modelling will be done in which we will create a simplified model of the system.
3. After that we will go through number of algorithm which could be used in the development of the system in an effective way.
4. Lastly we will develop the final prototype of the system.

#### ADVANTAGES

- Reliable
- Alert message
- Real time system.
- Cost efficient.

#### APPLICATION:

- Mining

#### METHODOLOGY

- Node MCU NodeMCU is an open source firmware for which open source prototyping board designs are available. The name "NodeMCU" combines "node" and "MCU" (micro-controller unit).[8]. The term "NodeMCU" strictly speaking refers to the firmware rather than the associated development kits.[citation needed Both the firmware and prototyping board designs are open source.[9] The firmware uses the Lua scripting language. The firmware is based on the eLua project, and built on the Espressif Non-OS SDK for ESP8266. It uses many open source projects, such as lua-cjson[10] and SPIFFS.[11] Due to resource constraints, users need to select the modules relevant for their project and build a firmware tailored to their needs. Support for the 32-bit ESP32 has also been implemented. The prototyping hardware typically used is a circuit board functioning as a dual in-line package (DIP) which integrates a USB controller with a smaller surface-mounted board containing the MCU and antenna. The choice of the DIP format allows for easy prototyping on breadboards. The design was initially based on the ESP-12 module of the ESP8266, which is a Wi-Fi SoC integrated with a Tensilica Xtensa LX106 core, widely used in IoT applications (see related projects).

- Location Detection Module The Atmel 8-bit AVR RISC-based microcontroller combines 32 KB ISP flash memory with read-while-write capabilities, 1 KB EEPROM, 2 KB SRAM, 23 general-purpose I/O lines, 32 general-purpose working registers, 3 flexible timer/counters with compare modes, internal and external interrupts, serial programmable USART, a byte-oriented 2-wire serial interface, SPI serial port, 6-channel 10-bit A/D converter (8 channels in TQFP and QFN/MLF packages), programmable watchdog timer with internal oscillator, and 5 software-selectable power-saving modes. The device operates between 1.8 and 5.5 volts. The device achieves throughput approaching 1 MIPS/MHz.

- DHT11 DHT (sometimes stylized as D.H.T., acronym for Dance House Trance) were a Belgian duo consisting of singer Edm'ee Daenen (born 25 March 1985 in Kortrijk) and Flor Theeuwes, also known as DJ Da Rick (born 28 August 1976 in Turnhout). They had a hit in the US and Australia in 2005, with their cover version of "Listen to Your Heart", originally recorded by Roxette. The track reached number seven on the UK Singles Chart in December of that year.[2] Marketing of the song often referenced DHT as an acronym for Definite Hit Track. On 14 June, 2019, the duo unveiled a previously unreleased album, titled 2 on Apple Music, Spotify, and other music portals.

## CONCLUSION

We have planned to design a system for coal mine areas named as Coal Mine Safety Monitoring and Alert System. These system detects problem of coal mine employees who works underground. A real time monitoring system is developed to provide clearer and more point to point perspective of the underground mine. This system is displaying the parameters on the monitoring unit; it will be helpful to all miners present inside the mine to save their life before any casualty occurs. Alarm triggers when sensor values crosses the threshold level. This system also stores all the data in the computer for future inspection.

## REFERENCES

- [1] R. Agrawal, T. Imieliński, and A. Swami. Mining Association Rules between Sets of Items in Large Databases. Proc. Conf. on Management of Data, 207-216. ACM Press, New York, NY, USA 1993
- [2] A. Agrawal, H. Mannila, R. Srikant, H. Toivonen, and A. Verkamo. Fast Discovery of Association Rules, pages 307-328 in: U.M. Fayyad, G. Piatetsky-Shapiro, P. Smyth, and R. Uthurusamy, eds. Advances in Knowledge Discovery and Data Mining. AAAI Press / MIT Press, Cambridge, CA, USA 1996.
- [3] J. Han, H. Pei, and Y. Yin. Mining Frequent Patterns without Candidate Generation. Proc. Conf. On the Management of Data (SIGMOD'00, Dallas, TX). ACM Press, New York, NY, USA 2000
- [4] M. Zaki, S. Parthasarathy, M. Ogihara, and W. Li. New Algorithms for Fast Discovery of Association Rules. Proc. 3rd Int. Conf. on Knowledge Discovery and Data Mining (KDD'97, Newport Beach, CA), 283-296. AAAI Press, Menlo Park, CA, USA 1997.
- [5] Keeping Things Simple: Finding Frequent Item Sets by Recursive Elimination Christian Borgelt. Workshop Open Source Data Mining Software (OSDM'05, Chicago, IL), 66-70. ACM Press, New York, NY, USA 2005
- [6] Pranjal Hazarika, "implementation of safety helmet for coal mine workers", 1st IEEE International Conference on Power Electronics Intelligent Control and Energy Systems, pp. 1-3, 201

