

# Energy conservation

## *Energy conserving chair*

Ashvin Madanlal Maheshwari

Lecturer

Electrical Engineering Department, Government Polytechnic, Dahod, India

**Abstract - Energy conservation refers to efforts made to reduce energy consumption in all aspects. Energy conservation can be achieved through increased efficient energy use, in conjunction with decreased energy consumption and/or reduced consumption from conventional energy sources. Energy conservation can result in increased financial capital, environmental quality, national security, personal security, and human comfort. Individuals and organizations that are direct consumers of energy choose to conserve energy to reduce energy costs and promote economic security. Industrial and commercial users can increase energy use efficiency to maximize profit. An energy crisis is any great bottleneck (or price rise) in the supply of energy resources to an economy. In popular literature though, it often refers to one of the energy sources used at a certain time and place, particularly those that supply national electricity grids or serve as fuel for vehicles. There has been an enormous increase in the global demand for energy in recent years as a result of industrial development and population growth. Supply of energy is, therefore, far less than the actual demand. In government and private sector so much electrical energy is wasted. So if we will design certain appliance by which we can save energy when not required. So here is one idea how to conserve the electrical energy by using energy conserving chair.**

### I. INTRODUCTION

Life on Earth is driven by energy. Autotrophs take it from solar radiation and heterotrophs take it from autotrophs. Energy captured slowly by photosynthesis is stored up, and as denser reservoirs of energy have come into being over the course of Earth's history, heterotrophs that could use more energy evolved to exploit them, Homo sapiens is such a heterotroph; indeed, the ability to use energy extra somatically (outside the body) enables human beings to use far more energy than any other heterotroph that has ever evolved. The control of fire and the exploitation of fossil fuels have made it possible for Homo sapiens to release, in a short time, vast amounts of energy that accumulated long before the species appeared.

By using extra somatic energy to modify more and more of its environment to suit human needs, the human population effectively expanded its resource base so that for long periods it has exceeded contemporary requirements. This allowed an expansion of population similar to that of species introduced into extremely, propitious new habitats, such as rabbits in Australia or Japanese beetles in the United States. The world's present population of over 7-billion is sustained and continues to grow through the use of extra somatic energy. But the exhaustion of fossil fuels, which supply three quarters of this energy, is not far off, and no other energy source is abundant and cheap enough to take their place.

The energy which is widely used today is in the form of electrical energy. And this is so because of the following advantage it has on the other forms of energy.

- Electrical energy could be considered as the most convenient form of energy. It could be converted from one form into any other form.
- The machines or devices which works on electrical energy can easily be controlled i.e. an electric motor could be switch on and off with in a very easy manner where as a mechanical engine needs much energy to get started. And we could provide much easy way to control machines with help of electric devices such as regulators, voltage controllers etc.
- Another important aspect of electricity is the flexibility; it is very easy to carry electricity from one place to other by using conductors.
- Electrical energy is much cheaper compared to other forms of energy. The cost of production and availability is much larger compared to other forms of energy and hence it is an inevitable component in all sectors of the modern world.
- Electrical energy is not associated with polluting factors such as smoke, dust, fumes ,poisonous gases etc thus it offers a healthy atmosphere to each and all living organism in the world.
- The transmission efficiency of electrical energy is much higher. The electrical energy is produced in centers called generating station and is supplied to the domestic and industrial use by means of transmission lines and other important devices like transformers, transmission towers, electric posts etc
- From the above, no need to conclude that, electricity is the most efficient and superior form of energy available to us. But still, like other forms of energy, there are some drawbacks in its own form as well. Some of them are as follows,
- It is not a self sustainable source of power.
- Electrical frequencies can be easily disrupted by magnets. This problem is mostly observed in the utilization of electrical power in the electrical equipments like motors and other electromagnetic equipments.

- It produces a great amount of heat (energy) making containing and transporting (wires). This problem occurs in the distribution lines due to the resistance, inductive reactance and capacitive reactance of the distribution lines. So for efficient utilization of electrical power it becomes important to reduce this loss as much as possible.
- The entire industrialized world completely relies on electricity so without electricity progress would slow to a crawl. To overcome this problem effective alternative of electrical power should be found. But, it seems little bit of difficult.
- It isn't as effective as other types of energy, specifically nuclear energy.

However whatever is the reason but it's the form which is widely used. Now as mentioned above, world population is rising day by day. So the energy demands are also increasing due to this the natural resources are shrinking down at a very faster rate. In these circumstances, if proper consideration is not given then soon human kind will not have any resources of energy to use. This problem has been named as "energy crisis" and the whole concept has been explained later in this report. Along with the development of energy crisis, there has been a need to save energy sources and use the energy judiciously and so the result is the

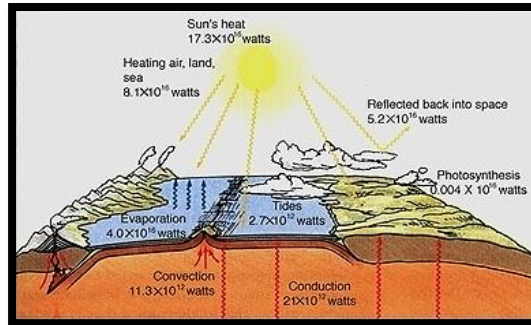

Fig 1 concept of "energy conservation".

With this paper of "electricity conserving chair", an attempt has been made by us to conserve electrical energy by preventing its unnecessary wastage. In India, when wastage of electrical energy is talked about then generally government and public premises comes in mind. However, this model can also help us in order to save electricity in abodes as well

## II. HISTORY

The word energy derives from Greek, which appears for the first time in the work Nicomachean Ethics of Aristotle in the 4th century BCE.

Without energy, life does not exist. All forms of life extract energy from the environment and convert it to forms which can be used. Our environment has three primary energy sources

- Solar energy
  - radiant energy
  - $17.3 \times 10^{16}$  watts
- energy the Earth's interior
  - geothermal energy
  - $32.3 \times 10^{12}$  watts
- planetary energy
  - energy of gravitational attraction
  - tides
  - $2.7 \times 10^{12}$  watts

The concept of energy emerged out of the idea of vis viva (living force), which Leibniz defined as the product of the mass of an object and its velocity squared; he believed that total vis viva was conserved. To account for slowing due to friction, Leibniz claimed that heat consisted of the random motion of the constituent parts of matter — a view shared by Isaac Newton, although it would be more than a century until this was generally accepted.

Emilie marquise du Châtelet in her book Institutions de Physique ("Lessons in Physics"), published in 1740, incorporated the idea of Leibniz with practical observations of Gravesande to show that the "quantity of motion" of a moving object is proportional to its mass and the square of its velocity (not the velocity itself as Newton taught—what was later called momentum).

In 1802 lectures to the Royal Society, Thomas Young was the first to use the term "energy" in its modern sense, instead of vis viva.[2] In the 1807 publication of those lectures, he wrote,

The product of the mass of a body into the square of its velocity may properly be termed its energy.[3]

Gustave-Gaspard Coriolis described "kinetic energy" in 1829 in its modern sense, and in 1853, William Rankine coined the term "potential energy."

It was argued for some years whether energy was a substance (the caloric) or merely a physical quantity.

The development of steam engines required engineers to develop concepts and formulas that would allow them to describe the mechanical and thermal efficiencies of their systems. Engineers such as Sadi Carnot, physicists such as James Prescott Joule, mathematicians such as Emilee Chaperon and Hermann, and amateurs such as Julius Robert von Mayer all contributed to the notion that the ability to perform certain tasks, called work, was somehow related to the amount of energy in the system. In the 1850s, Glasgow professor of natural philosophy William Thomson and his ally in the engineering science William Rankine began to

replace the older language of mechanics with terms such as "actual energy", "kinetic energy", and "potential energy".[4] William Thomson (Lord Kelvin) amalgamated all of these laws into the laws of thermodynamics, which aided in the rapid development of explanations of chemical processes using the concept of energy by Rudolf Clausius, Josiah Willard Gibbs and Walther Nernst. It also led to a mathematical formulation of the concept of entropy by Clausius, and to the introduction of laws of radiant energy by Jožef Stefan. Rankine, coined the term "potential energy".[4] In 1881, William Thomson stated before an audience that:[5]

The very name energy, though first used in its present sense by Dr Thomas Young about the beginning of this century, has only come into use practically after the doctrine which defines it had ... been raised from mere formula of mathematical dynamics to the position it now holds of a principle pervading all nature and guiding the investigator in the field of science.

Over the following thirty years or so this newly developing science went by various names, such as the dynamical theory of heat or energetic, but after the 1920s generally came to be known as thermodynamics, the science of energy transformations.

Stemming from the 1850s development of the first two laws of thermodynamics, the science of energy have since branched off into a number of various fields, such as biological thermodynamics and thermo economics, to name a couple; as well as related terms such as entropy, a measure of the loss of useful energy, or power, an energy flow per unit time, etc. In the past two centuries, the use of the word energy in various "non-scientific" vocations, e.g. social studies, spirituality and psychology has proliferated the popular literature.

Humans convert energy from forms that are less desirable to those that are more desired i.e. from grass to meat, from wood to heat and from fossil fuels to electricity. Throughout history, man has developed ways to expand his ability to harvest energy. The primitive man found in East Africa 1,000,000 years ago, who had yet to discover fire, had access only to the food he ate so his daily energy consumption has been estimated at 2,000 Kcal or 2,000 dietary calories. Energy consumption of the hunting man found in Europe about 100,000 years ago was about 2.5 times that of the primitive man because he had better methods of acquiring food and also burned wood for both heating and cooking. Energy consumption increased again by almost 2.5 times as man evolved into the primitive agricultural man of about 5,000 years ago who harnessed draft animals to aid in growing crops. The advanced agricultural man of 1400 A.D. northwestern Europe again doubled the amount of energy consumption as he began inventing devices to tap the power of wind and water began to utilize small amounts of coal for heating and harnessed animals to provide transportation. The dawn of the age of industrialization, ushered in by the invention of the steam engine, caused a 3-fold increase in energy consumption by 1875. Among other things, the steam engine allowed man to unlock the Earth's vast concentrated storage deposits of solar energy - coal, gas and oil so he no longer was limited to natural energy flows. Whereas increases in energy consumption had been gradual throughout history, once industrialization occurred, the rate of consumption increased dramatically over a period of just a few generations. The technological man of 1970 in the U.S. consumed approximately 230,000 Kcal of energy per day (~115 times that of primitive man) with about 26% of that amount being electrical energy. Of that electrical energy only about 10% resulted in useful work while the remaining 16% was wasted by inefficiencies in electrical generation and transmission. The change in energy consumption patterns over time are shown in Figure 1 below.

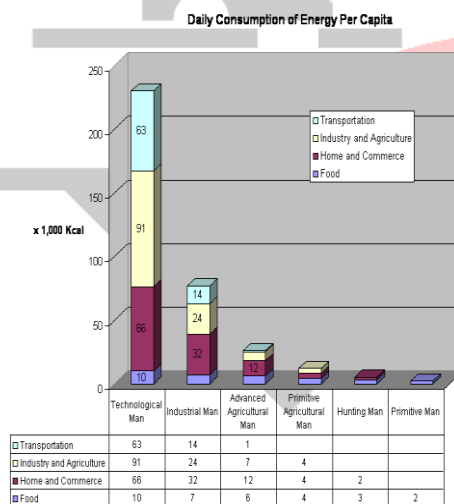
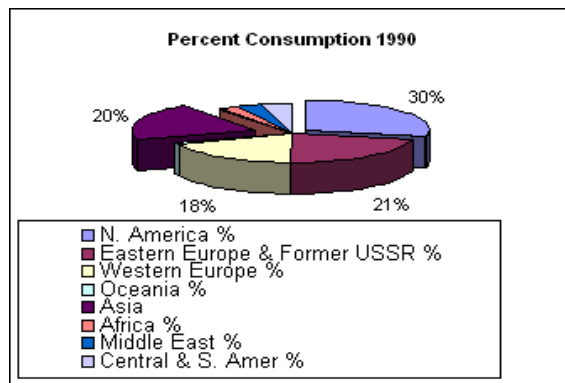

Figure 1 Estimated Daily Consumption of Energy per Capita at Different Historical Points  
Adapted from: E. Cook, "The Flow of Energy in an Industrial Society" Scientific American, 1971 p. 135.

If you look at how energy sources have changed over time, you will notice that the age of industrialization and to an even greater extent the age of technology have accelerated the appearances and exploitation of new energy sources.

**World-wide Energy Consumption**



The success of an industrial society i.e., the growth of its economy, the quality of the life-style of the population and the society's impact on the environment, is a function of the quantities and types of energy resources it exploits and the efficiency with which it converts potential energy into work and heat. Increasing energy consumption closely matches societal modernization.

Figure 7 shows that during the period 1980 -2002, North America was the greatest consumer of energy in the world. The two regions that show the greatest change over that period are Asia and Eastern Europe and the former Soviet Union. While Asia's energy consumption has increased dramatically, that of Eastern Europe and the former Soviet Union has declined

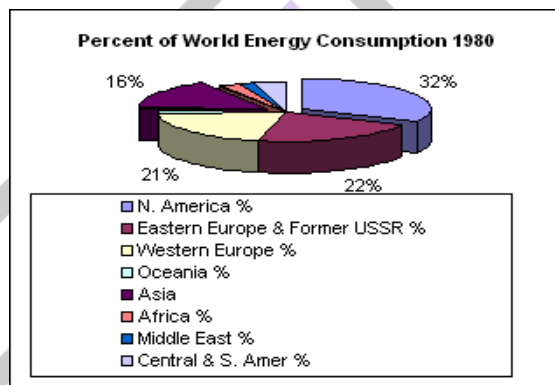

Figure 7. Percentage of World Energy Consumption By Region 1980-2002  
Data obtained from the Energy Information Administration

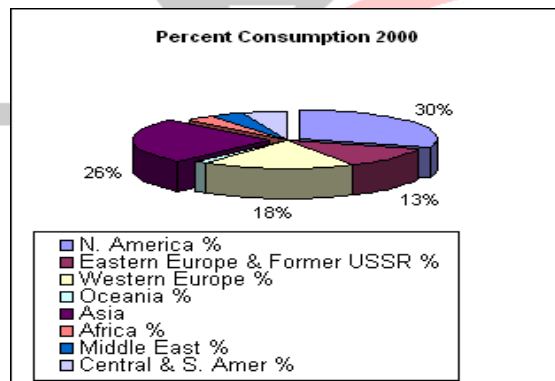

Figure 8. Percentage of total Energy Consumption By Region in Select Years  
Data obtained from the Energy Information Administration

### III. ENERGY CONSERVATION AND ITS IMPORTANCE

Energy conservation refers to efforts made to reduce energy consumption. Energy conservation can be achieved through increased efficient energy use, in conjunction with decreased energy consumption and/or reduced consumption from conventional energy sources. An energy conservation act was passed in 2001.[clarification needed]

Energy conservation can result in increased financial capital, environmental quality, national security, personal security, and human comfort Individuals and organizations that are direct consumers of energy choose to conserve energy to reduce energy costs and promote economic security. Industrial and commercial users can increase energy use efficiency to maximize profit.

In passive solar building design, windows, walls, and floors are made to collect, store, and distribute solar energy in the form of heat in the winter and reject solar heat in the summer. This is called passive solar design or climatic design because, unlike active solar heating systems, it doesn't involve the use of mechanical and electrical devices.

The key to designing a passive solar building is to best take advantage of the local climate. Elements to be considered include window placement and glazing type, thermal insulation, thermal mass, and shading. Passive solar design techniques can be applied most easily to new buildings, but existing buildings can be adapted or "retrofitted".

By reducing emissions, energy conservation is an important part of lessening climate change. Energy conservation facilitates the replacement of non-renewable resources with renewable energy. Energy conservation is often the most economical solution to energy shortages, and is a more environmentally being alternative to increased energy production.

Petroleum Conservation Research Association (PCRA) [www.pcra.org](http://www.pcra.org) is an Indian government body created in 1977 and engaged in promoting energy efficiency and conservation in every walk of life. In the recent past PCRA has done mass media campaigns in television, radio & print media. An impact assessment survey by a third party revealed that due to these mega campaigns by PCRA, overall awareness level have gone up leading to saving of fossil fuels worth crores of rupees besides reducing pollution.

Bureau of Energy Efficiency is an Indian governmental organization created in 2001 responsible for promoting energy efficiency and conservation.

The use of telecommuting by major corporations is a significant opportunity to conserve energy, as many Americans now work in service jobs that enable them to work from home instead of commuting to work each day.[6]

Electric motors consume more than 60% of all electrical energy generated and are responsible for the loss of 10 to 20% of all electricity converted into mechanical energy.

Consumers are often poorly informed of the savings of energy efficient products. The research one must put into conserving energy often is too time consuming and costly when there are cheaper products and technology available using today's fossil fuels.[8] Some governments and NGOs are attempting to reduce this complexity with ecolabels that make differences in energy efficiency easy to research while shopping.

Technology needs to be able to change behavioral patterns, it can do this by allowing energy users, business and residential, to see graphically the impact their energy use can have in their workplace or homes. Advanced real-time energy metering is able to help people save energy by their actions. Rather than become wasteful automatic energy saving technologies, real-time energy monitors and meters such as the Energy Detective, Enigin Plc's Eniscope, Ecowizard, or solutions like EDSA's Paladin Live are examples of such solutions.

It is frequently argued that effective energy conservation requires more than informing consumers about energy consumption, for example through smart meters at home or ecolabels while shopping. People need practical and tailored advice how to reduce energy consumption in order to make change easy and lasting. This applies to both efficiency investments, such as investment in building renovation, or behavioral change, for example turning down the heating. To provide the kind of information and support people need to invest money, time and effort in energy conservation, it is important to understand and link to people's topical concerns.

Some retailers argue that bright lighting stimulates purchasing. However, health studies have demonstrated that headache, stress, blood pressure, fatigue and worker error all generally increase with the common over-illumination present in many workplace and retail settings. It has been shown that natural day lighting increases productivity levels of workers, while reducing energy consumption.

To avoid the serious social and economic implications a global decline in oil production could entail, the 2005 Hirsch report emphasized the need to find alternatives, at least ten to twenty years before the peak, and to phase out the use of petroleum over that time. This was similar to a plan proposed for Sweden that same year. Such mitigation could include energy conservation, fuel substitution, and the use of unconventional oil. Because mitigation can reduce the use of traditional petroleum sources, it can also affect the timing of peak oil and the shape of the Hubbert curve.

#### IV. WORKING PRINCIPLE OF CIRCUIT

The whole circuit works on the combined working of three different circuits. The circuits have been named below with their functions in brief.

1. Time delay circuit- produces the required time lag in switching of the supply
2. Temperature sensitive circuit/switch- switches on the fan when temperature in the surrounding exceeds the preset limit.
3. Light sensitive circuit/switch- switches on the tube light when light intensity in the surrounding falls below the preset limit.

#### V. BLOCK DIAGRAM OF CIRCUIT

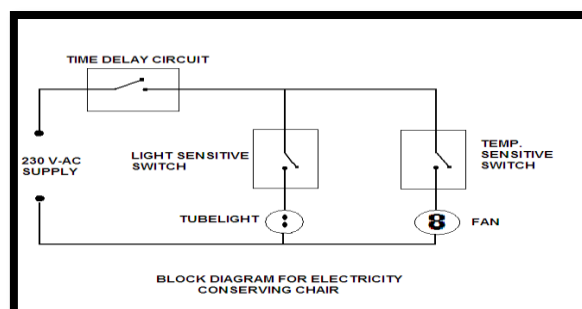

As shown in the block diagram above, the circuit for energy conserving chair consist of three different circuits. The circuits are named as following,

1. Time delay circuit
2. Light sensitive circuit and
3. Temperature sensitive switch

Now, the delay circuit provides the required time lag for proper functioning of the circuit. When someone sits on the chair then the push button gets pressed up which actuates the delay circuit and thus first circuit is activated and when the person leaves the chair, the push button opens and once the switch opens then after the set time the relay in the delay circuit opens which interrupts the supply to the fan and light gets switched off.

When someone sits on the chair then the delay circuit operates and the supply is available for the light and but they cannot operate as long as the relay in light sensitive circuit and temperature switch remains open for light and fan respectively. Relay in the light sensitive switch gets closed only when the surrounding light intensity is less than the present level and similarly, the fan switches on only when the surrounding temperature increases beyond the preset magnitude.

Thus in this way the light and fans are operated to prevent the unnecessary wastage of electrical energy.

#### List of components used

1. Batteries
2. 555 timer IC
3. Darlington IC
4. LM324 comparator IC
5. 6V DC relays
6. Resistors and variable resistors
7. Transformer 230/12 volt Ac
8. Diodes and Zener diodes
9. LDR(light sensor) and LM35 sensor(heat sensor)

The datasheet of some important components has been provided later In the report for readers' reference.

#### VI. WORKING OF CIRCUIT

As stated above in the block diagram of this project, this chair works under the combined effect of three different circuits. So in order to understand the whole working of the circuit, we need to understand each circuit separately.

##### 1. Time delay circuit

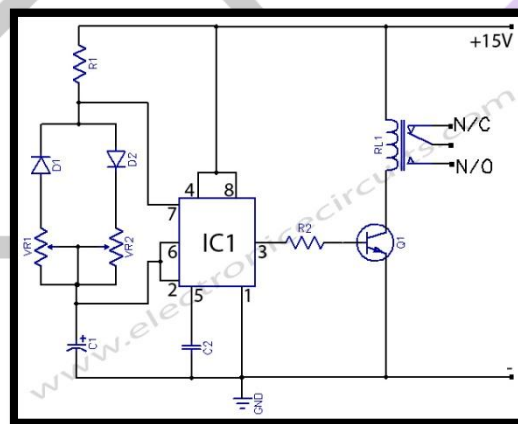

(Circuit diagram for time delay circuit)

Comparator 1 has a threshold input (pin 6) and a control input (pin 5). In most applications, the control input is not used, so that the control voltage equals  $+2/3 VCC$ . Output of this comparator is applied to set (S) input of the flip-flop. Whenever the threshold voltage exceeds the control voltage, comparator 1 will set the flip-flop and its output is high. A high output from the flip-flop saturates the discharge transistor and discharge the capacitor connected externally to pin 7. The complementary signal out of the flip-flop goes to pin 3, the output. The output available at pin 3 is low. These conditions will prevail until comparator 2 triggers the flip-flop. Even if the voltage at the threshold input falls below  $2/3 VCC$  that is comparator 1 cannot cause the flip-flop to change again. It means that the comparator 1 can only force the flip-flop's output high.

To change the output of flip-flop to low, the voltage at the trigger input must fall below  $+1/3 Vcc$ . When this occurs, comparator 2 triggers the flip-flop, forcing its output low. The low output from the flip-flop turns the discharge transistor off and forces the power amplifier to output a high. These conditions will continue independent of the voltage on the trigger input. Comparator 2 can only cause the flip-flop to output low.

From the above discussion it is concluded that for the having low output from the timer 555, the voltage on the threshold input must exceed the control voltage or  $+2/3 VCC$ . They also turn the discharge transistor on. To force the output from the timer high, the voltage on the trigger input must drop below  $+1/3 VCC$ . This also turns the discharge transistor off.

A voltage may be applied to the control input to change the levels at which the switching occurs. When not in use, a 0.01 nano Farad capacitor should be connected between pin 5 and ground to prevent noise coupled onto this pin from causing false triggering.

Connecting the reset (pin 4) to a logic low will place a high on the output of flip-flop. The discharge transistor will go on and the power amplifier will output a low. This condition will continue until reset is taken high. This allows synchronization or resetting of the circuit's operation. When not in use, reset should be tied to +VCC.

Here the 555 timer IC is used as mono stable vibrator and the IC works in the following manner as mono stable timer.

A monostable multivibrator (MMV) often called a one-shot multivibrator, is a pulse generator circuit in which the duration of the pulse is determined by the R-C network, connected externally to the 555 timer. In such a vibrator, one state of output is stable while the other is quasi-stable (unstable). For auto-triggering of output from quasi-stable state to stable state energy is stored by an externally connected capacitor C to a reference level. The time taken in storage determines the pulse width. The transition of output from stable state to quasi-stable state is accomplished by external triggering. The schematic of a 555 timer in monostable mode of operation is shown in figure.

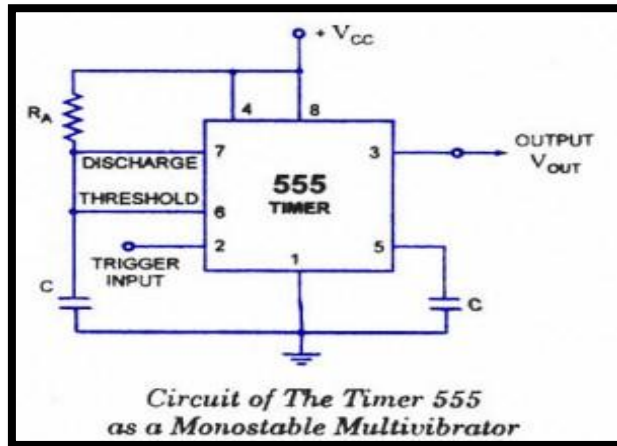

The capacitor C has to charge through resistance RA. The larger the time constant RAC, the longer it takes for the capacitor voltage to reach +2/3VCC.

In other words, the RC time constant controls the width of the output pulse. The time during which the timer output remains high is given as

$$t_p = 1.0986 RAC$$

where RA is in ohms and C is in farads. The above relation is derived as below. Voltage across the capacitor at any instant during charging period is given as

$$v_c = VCC (1 - e^{-t/RAC})$$

Substituting  $v_c = 2/3 VCC$  in above equation we get the time taken by the capacitor to charge from 0 to +2/3VCC.

$$\text{So } +2/3VCC = VCC (1 - e^{-t/RAC}) \text{ or } t = RAC \log_e 3 = 1.0986 RAC$$

$$\text{So pulse width, } t_p = 1.0986 RAC \text{ s } \approx 1.1 RAC$$

**2. Light dependent switch/circuit**

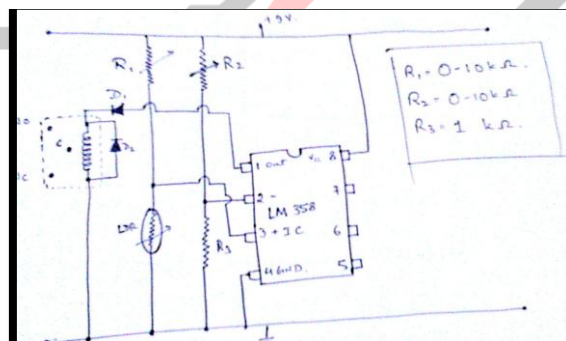

(circuit diagram for light sensitive switch)

This circuit has got an LDR, one comparator IC, one amplifier, one 6 volt relay and a battery of 9 V for controlling of the circuit. A constant voltage is applied to the non inverting end of the comparator and the same voltage is given to the inverting end as well, but an LDR is connected between the non-inverting and ground terminal of the comparator IC. When the resistance of LDR increases during the night time, the input voltage to the non inverting terminal of the comparator input increases as compared to the inverting terminal. Due to this the output of the IC goes high to operate the relay and to switch on the external load ie the tube light similarly in the day light ground the voltage of the non inverting terminal of the IC . So comparatively, voltage on the inverting terminal becomes greater than the non inverting terminal. so finally the load remains off during the day time.

**3. Temperature sensitive circuit/switch**

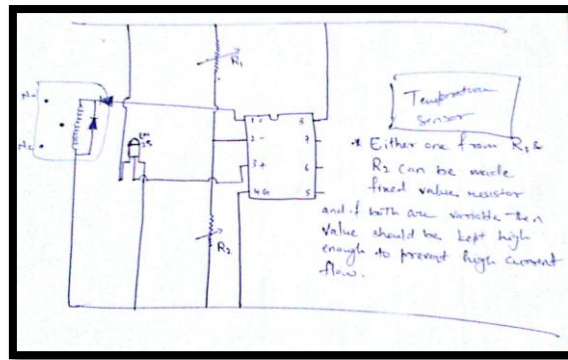

(Circuit diagram for heat sensitive switch)

Similar to the light sensitive circuit, this circuit also comprises of a comparator, relay and other components apart from this, a transformer has been used to provide a constant voltage of 9V to the circuit, and Darlington IC has been used to control the working current of the relay. A LM35 heat sensor has been employed to sense the surrounding temperature. The output of the sensor increases by 10mV for every degree Celsius of temperature. So the output characteristic of this sensor is linear one. Then the output voltage increases due to the increment in the surrounding temperature, the output is given to the non inverting terminal of the comparator IC so the output signal of comparator IC goes high. This high input of the comparator IC is given to the input terminal of the Darlington IC and so it starts to conduct the current through the relay coil. The relay operates and the contact of the output load i.e. the fan gets closed. Similarly, when the surrounding temperature goes down then the output voltage of the LM35 sensor also gets reduced. When the output voltage of LM35 reduces then the voltage on the non-inverting input terminal of the comparator also reduces with comparison to the reference voltage on the inverting terminal of the comparator. This makes the output voltage zero so the relay contacts opens to shut down the power supply to the load.

## VII. ADVANTAGES

1. It helps to conserve a great amount of electrical energy which generally gets wasted due to negligence and lack of proper attention.
2. It provides automatic control for switching light and fans
3. The circuit is economical and easy to construct as the components used up for the circuit is economical and easily available.
4. There is no need to install expensive motion sensors or thermal sensors to get the same result.

## VIII. DISADVANTAGES

1. Will require a slight alternation in the design of the chair
2. The above will tend to make the chair to cost more due to the implementation of spring mechanism and required circuits.
3. This type of chair cannot be made mobile so they have to be fixed firmly on the floor.
4. In the present state and arrange of the chair it requires a protective sheet to prevent the circuit from any potential damage. So, great care has to be taken.

## IX. CONCLUSION

Imagination is more important than Knowledge, for knowledge is limited, Whereas imagination embraces the Entire world – stimulating progress,

Giving birth to evolution. — Albert Einstein

To make sure we have plenty of energy in the future, it's up to all of us to use energy wisely. We must all conserve energy and use it efficiently. It's also up to those who will create the new energy technologies of the future. All energy sources have an impact on the environment. Concerns about the greenhouse effect and global warming, air pollution, and energy security have led to increasing interest and more development in renewable energy sources such as solar, wind, geothermal, wave power and hydrogen. But we'll need to continue to use fossil fuels and nuclear energy until new, cleaner technologies can replace them. One of you who is reading this might be another Albert Einstein or Marie Curie and find a new source of energy. Until then, it's up to all of us.

The future is ours, but we need energy to get there.

## REFERENCES

- [1] Encyclopedia of energy engineering and technology - edited by Barney L. Capehart
- [2] A book of Electronic circuit: Discrete and Integrated By Donald Schillings and Charles Belove, third edition
- [3] A book of Op – Amps and Linear integrated circuit By Ramakant A Gaykwad, Fourth edition
- [4] A book of Industrial and Power electronics By G K Mithal and Dr Maneesha Gupta, Nineteenth edition.
- [5] A simple circuit, www.electronicforyou.com