

# Comparison of Different Burst Switching Techniques for High Speed Network

<sup>1</sup>Asst. Prof. Margam K. Suthar, <sup>2</sup>Asst. Prof. Dhaval R. Sathawara

<sup>1</sup>Assistant Professor, <sup>2</sup>Assistant Professor

<sup>1</sup>Post Graduate Research Centre for Mobile Computing and Wireless Technologies,  
Gujarat Technological University, Nr, Vishwakarma Govt Engineering College, Nr. Visat Three Roads, Visat-Gandhinagar  
Highway, Chandkheda, Ahmedabad-382424. Gujarat.

<sup>2</sup>Department of Electronic and Communication Engineering  
U.V.Patel collage of engineering, Ganpat University Kherva (Mehsana), India

**Abstract**— In first generation optical networks, optical fibers provided only point-to-point connections. Entire potential of the fiber could not be utilized, because the electronic routers operate at a much lower speed than the fiber capacity. Wavelength division multiplexing (WDM) technology, were deployed in the second generation optical networks and in second generation contain three switching techniques 1) Circuit switching 2) Packet switching 3) Burst switching.). Optical burst switching combines the best features of circuit and packet switching and – hopefully - avoids the worst of both. *Optical burst switching (OBS)* is the promising area it can meet the bandwidth requirement of bandwidth intensive application. OBS is switching technique for the next generation optical networks. However, there are certain issues such as burst aggregation, scheduling, contention resolution and QoS that needs to be addressed in OBS. In this paper, we summarize the results of current research trends on optical burst switching networks. We present the classification of different scheduling algorithms and contention resolution techniques.

**Index Terms**— Wavelength division multiplexing (WDM) , *Optical burst switching (OBS)*.

## I. INTRODUCTION

There have been a phenomenal increase in the demand for bandwidth over the years due to rapid growth in the number of Internet users and increase in bandwidth intensive applications such as voice-over-IP, video conferencing, interactive video on demand, and many other multimedia applications [1]. Disadvantage of Copper Wire is to transmit large volumes of voice as well as data information over the large distances, such as delay, power, and bandwidth limitations. To meet the ever growing demand of bandwidth, copper cables were replaced by optical fibers [1].

Constant improvements in technology allow fiber optic networks to put more and more wavelengths of light on to the same physical fiber, which make fiber optic networks the ideal choice to deal with future traffic demands [2].

Optical fiber not only supports huge bandwidth but also have other advantages too such as lower bit-error rate, no interference problem and security advantage [5].

The first widely deployed optical networks were based on optical point-to-point links and electronic routers, with all multiplexing being done in the electrical domain. Use at telephony networks. According to L.G. Roberts. Internet growth trends, “For 18 years the data traffic doubled every twelve months”.

Since 1997, the rate of increase has increased, and today’s network traffic doubling every six months. The bandwidth offered by an optical fiber is enormous (large), several orders of magnitude bigger than this of twisted pair or coaxial cable.

Although not even close to utilizing the theoretical capabilities, the introduction of wavelength division multiplexing (WDM) made it apparent that the limiting factor would be not the transmission, but switching (electronic routers). Moore’s Law states that the “Processing power of computers doubles every eighteen months”. This means that the demand for bandwidth will always grow faster than the switching capabilities of electronic routers. The bandwidth problem can be alleviated (decrease) by the introduction of wavelength-switched, fully optical networks. Instead of performing optical to electrical to optical (OEO) conversion in each core router, a light path is set up for each connection (optical point-to-point). hear disadvantage is each connection requires its own wavelength, the number of concurrent connections originating at a given node is limited. This means that in a large network, it may be impossible to create full mesh of connections. Another factor is connection setup time.

In a wavelength- switched network this may be of the order of days if the network has to be reconfigured manually. Such a network will be incapable of reacting to changes in traffic loads. Evolution of Optical Networks shown in fig.1

Wavelength division multiplexing (WDM) technology, were deployed in the second generation optical networks. WDM divides the available bandwidth of the fiber into number of non-overlapping wavelength channels each operating at electronic speed. To carry IP traffic over WDM networks three switching technologies have been studied: optical circuit, packet switching and burst switching. Optical circuit switching and packet switching have their own limitations when applied to WDM networks [4]. Circuit switching is not bandwidth efficient unless the duration of transmission is greater than the circuit establishment period. On the other hand packet switching is hop-by-hop store and forward scheme and needs buffering and processing at each intermediate node [8]. It

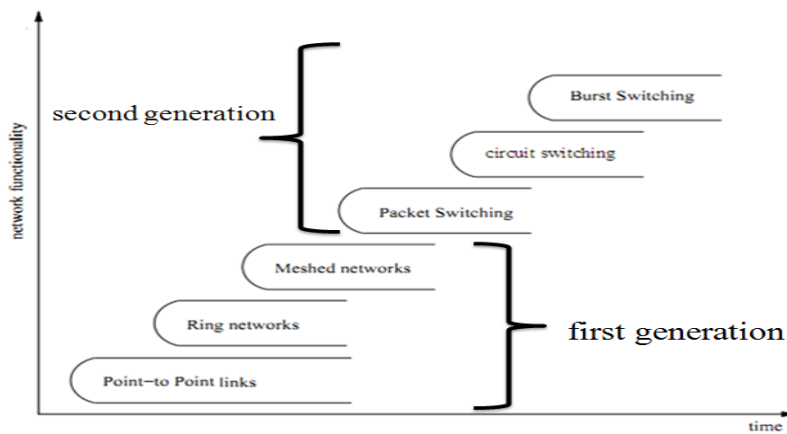

Fig.1: Evolution of Optical Networks

is flexible and bandwidth efficient. Fiber delay lines (FDL) have been proposed in literature to provide buffering. However, FDL have limited buffering capability and support only for a fixed duration [11].

In this context optical burst switching (OBS) is emerging as the alternative switching techniques, which combines the advantages of both circuit switching and packet switching. In OBS, a burst is the basic switching entity. Burst is a variable length data packet, assembled at an ingress router by aggregating a number of IP packets, which may be received from a single host or from multiple hosts belonging to the same or different access networks. A burst has two components: control and payload the control packet carries the header information. Thus, the control component incurs an overhead, referred to as control overhead. Payload is the actual data transmitted. Functional diagram of OBS [19] is shown in Fig. 2.

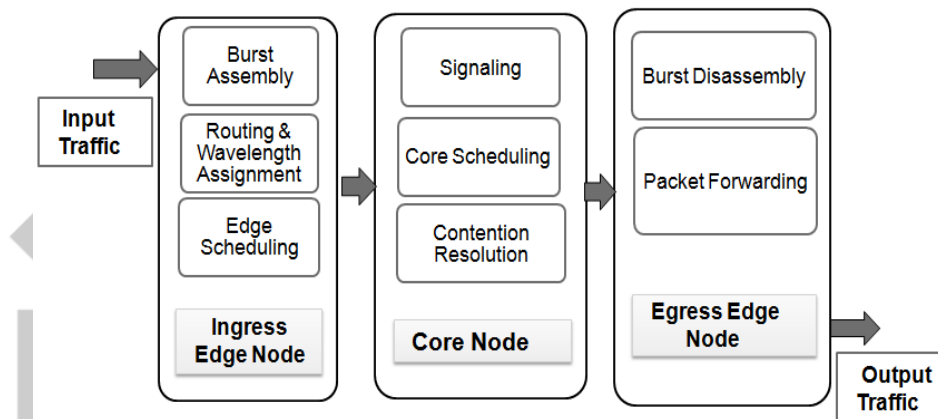

Figure 1: OBS Functional Diagram

The ingress node is responsible for burst assembly, routing, wavelength assignment, scheduling of burst at edge node. The core node is responsible for signaling, scheduling, resolving contention. The egress edge node is responsible for disassembling the burst and forwarding the packet to higher network layer [15].

## II. OPTICAL BREST SWITCHING

### A. Architecture

An optical burst-switched network composed with OBS nodes that are interconnected via optical fiber link. Architecture of an OBS networks is shown in Fig. 3: OBS network having two types of nodes: edge node and core node. Edge nodes are at the interface between the electronic and optical domain. Edge nodes can be an ingress or egress node. Packets are assembled into bursts at ingress edge node, which are then routed through the OBS network core node is mainly composed of an optical switching matrix and a switch control unit which is responsible to forward data burst.

A node in OBS network consists of both optical and electronic components. The optical components are multiplexers, demultiplexers and an optical switching network. The electronic components are input modules (1M), output module (OM), a control burst router (CBRT), and a scheduler. An optical burst switch control unit transfers an incoming data burst from an input port to its destination output port. When an edge node intends to transmit a data burst, it sends a control packet on the control wavelength to a core node. At core node, the control packet on the control channel is input to the corresponding 1M, which converts the control packet into electronic form. The control fields are extracted from the control packet. The CBRT uses these control fields to determine the next outgoing fiber for the corresponding payload by consulting a routing table maintained locally. The control packet is scheduled for transmission onto the selected outgoing link by the scheduler and the control packet is buffered until the scheduled time. The scheduler maintains a control packet queue. The scheduler also reserves wavelength on the determined links for the upcoming payload. The control packet is then forwarded on the OM, which updates its control fields and transmits it to the selected outgoing fiber using the optical transmitter. Just before the payload arrives, the switching element in the node is configured to connect the input port to the corresponding output port for the entire duration of the burst transmission. If the control packet is unable to reserve the wavelength then the control packet as well as payload is dropped [12].

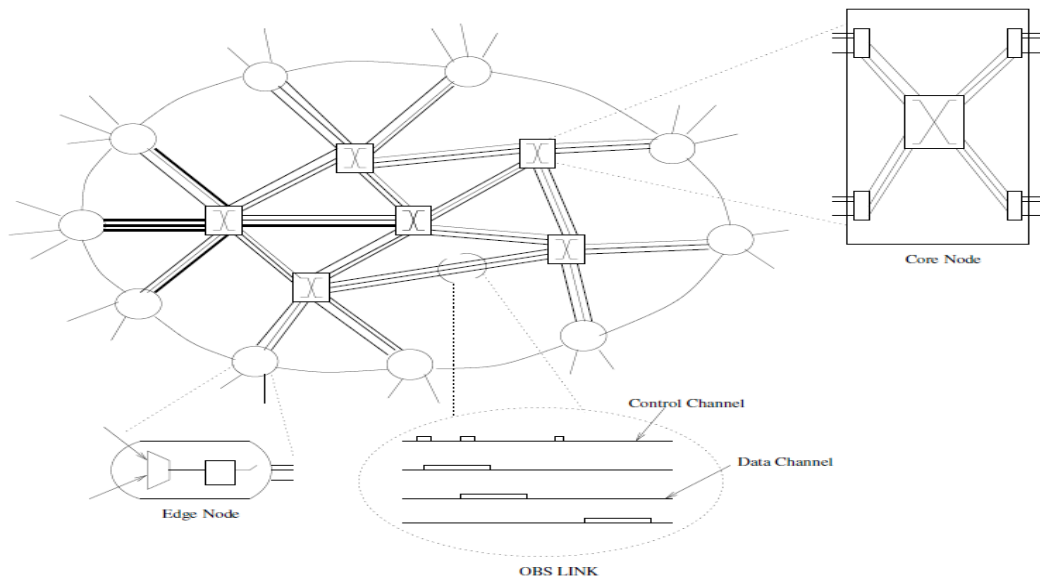

Figure 2 : Architecture of an OBS Network

### A. OBS Schemes

#### Burst Assembly Schemes

- A. Threshold based
- B. Timer-based.

Burst assembly is the process of assembling all incoming data burst at the edge node. Most widely used burst assembly schemes are threshold based and timer-based. In a timer based scheme, a timer is started at the Initialization of burst assembly. A data burst containing all packets in the buffer are generated when the timer exceeds the burst assembly period. A large time-out value results in a large packet and higher buffering delay at the edge node on the other hand; a too small value results in too many small bursts and a high electronic processing load. In a threshold-based scheme, a burst is created and sent into the OBS network when the total size of the packets in the queue reaches a threshold value. The shortcoming of the threshold-based scheme is that it does not provide any guarantee on the assembly delay that packets will experience. The choice of burst assembly algorithms depends on the type of traffic being transmitted. Timer-based algorithms are suitable for time-constrained traffic such as real-time applications because the upper bound of the burst assembly delay is limited. For a time-insensitive application such as file transmission, to reduce the overhead of control packets and increase OBS transmission efficiency, a threshold based scheme may be more appropriate [12].

**Timer based scheme**, a timer is started at the initialization of burst assembly. Buffers are generated when the timer exceeds the burst assembly period. Such Scheme are use when real-time applications.

**Threshold-based scheme**, a burst is created and sent into the OBS network when the total size of the packets in the queue reaches a threshold value. Threshold based Scheme use when time-insensitive application such as file transmission, to reduce the overhead of control packets and increase OBS transmission efficiency [12].

### B. Wavelength Reservation Schemes

Wavelength reservation refers to when and how the bandwidth is reserved and release. The reservation schemes in OBS network is adopted from ATM Block Transfer (ABT) .There are two versions of ABT: ABT with delayed transmission and ABT with immediate transmission. In an immediate transmission reservation scheme, an output wavelength is reserved for a payload immediately after the arrival of the corresponding control packet; if a wavelength cannot be reserved at that time, then the setup message is rejected and the corresponding data burst is dropped. In a delayed reservation scheme, the control packet and the payload are separated in time by an offset value in order to accommodate the processing of the control packet. An output wavelength is reserved for a data burst just before the arrival of the first bit of the data burst. If, upon arrival of the setup message, it is determined that no wavelength can be reserved at the appropriate time, then the setup message is rejected and the corresponding data burst is dropped. These two techniques have been adopted in OBS. Depending on bandwidth reservation, offset time and control management, three schemes for OBS implementation have been proposed: Tell-and-go (TAG), Just-in-time (JIT) and Just-enough-time (JET).

#### Tell-And-Go (TAG)

The control packet is transmitted on a control channel followed by a payload, on a data channel with zero or negligible offset. The payload is buffered using fiber delay line (FDL) while the control packet is processing at each intermediate node. If wavelength reservation is successful then the payload is transmitted along the reserved channel else the data burst is dropped and a negative acknowledgment (NAK) is sent to the source [12].

This is an immediate reservation scheme. In TAG, the control packet is transmitted on a control channel followed by a payload, on a data channel with zero or negligible offset. The payload is buffered using fiber delay line (FDL) while the control packet is processing at each intermediate node. If wavelength reservation is successful then the payload is transmitted along the reserved

channel else the data burst is dropped and a negative acknowledgment (NAK) is sent to the source. The source node sends a control packet after transmitting the payload to release the reserved resources along the path. The drawback of this scheme is availability of optical buffer. FDL can hold data only for a fixed duration and cannot accommodate data burst of variable size. Furthermore, loss of control packet to release reserved resources result in wastage of bandwidth [14].

#### Just-in-Time (JIT)

JIT is an immediate reservation scheme. Here, nodes reserve the resources as soon as the control packet is processed. Source transmits the payload after an offset time which is greater than the total processing time of control packet at intermediate nodes. If the resource is not available, the data burst is dropped. The difference between JIT and TAG is that in JIT the buffering of the payload at each node is eliminated by inserting a time slot between the control packet and the payload. The time slot is equal to the offset time. Since the bandwidth is reserved immediately after processing the control packet, the wavelength will be idle from the time the reservation is made till the first bit of the payload arrives at the node. This is because of the offset between the control packet and the payload. An in-band terminator is placed at the end of each data burst, which is used by each node to release the reserved wavelength after transmitting the payload [15].

Working of JIT is shown in Fig. 4. In this figure user A send a data burst to user B. Let  $t$  be the time a control packet arrives at some OBS node along the path to the destination. Let  $t_{\text{setup}}$  be the amount of time it takes an OBS node to process the control packet and  $t_{\text{offset}}$  be the offset value. The offset value depends on (i) the wavelength reservation scheme, (ii) number of nodes the control packet has already traversed, (iii) other factors, such as whether the offset is used for service differentiation [10].  $t_{\text{OXC}}$  is the amount of time it takes the OXC to configure its switch fabric to set up a connection from an input port to an output port. Once, the processing of the control packet is complete at time  $t + t_{\text{setup}}$ , a wavelength is immediately reserved for the upcoming data burst, and the operation to configure the OXC fabric to switch the data burst is initiated. When this operation completes at time  $t + t_{\text{setup}} + t_{\text{OXC}}$ , the OXC is ready to carry the data burst [10].

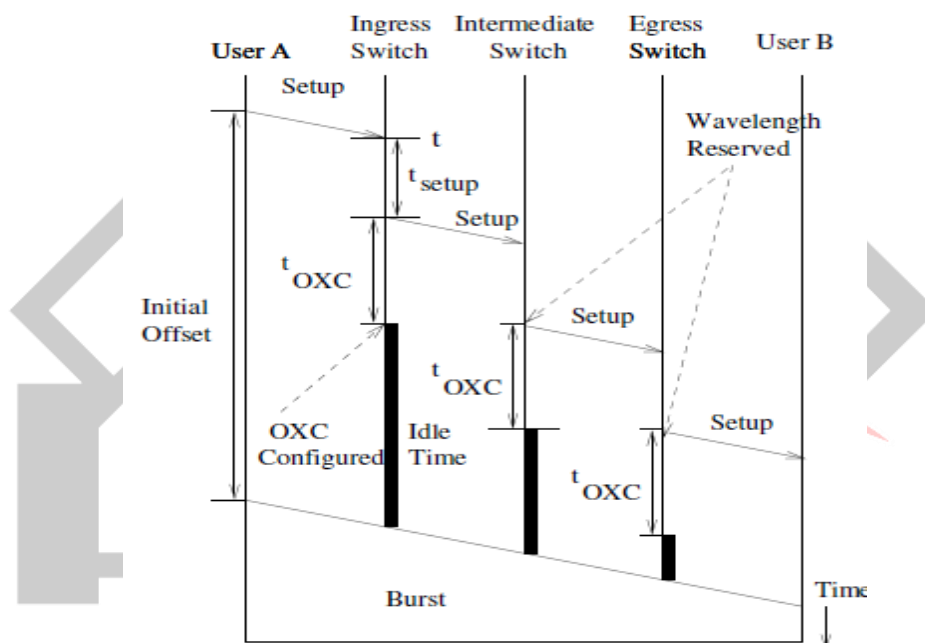

Figure 3 : Just-In-Time Reservation Scheme

Note that the data burst will not arrive at the OBS node until the time is  $(t + t_{\text{offset}})$ . As a result, the wavelength remains idle for a period of time equal to  $(t_{\text{offset}} - t_{\text{setup}} - t_{\text{OXC}})$ . Since the offset value decreases along the path to the destination, deep inside the network for an OBS node, will have shorter idle time between the instant OXC is configured and the arrival of first bit of payload [10].

#### Just-Enough-Time (JET)

JET is a delayed reservation scheme. Here, the size of the data burst is decided before the control packet is transmitted by the source. The offset between control packet and payload is also calculated based on the hop count between the source and destination. At each node, if bandwidth is available, the control packet reserves wavelength for the upcoming data burst for a fixed duration of time. The reservation is made from the time when the first bit of payload reaches the node till the last bit of payload is transmitted to the output port. This eliminates the wavelength idle time. This is the basic difference between JET and JIT. Since the wavelength is reserved for a fixed duration, there is no need for explicit release of reserved resources along the path. Since there is no wastage of bandwidth in this scheme, channel utilization is higher than other schemes. TAG and JIT schemes are significantly simpler than JET since they do not involve complex scheduling or void filling algorithms. Previous studies have shown that JET performs better than either JIT or TAG in terms of burst loss probability.

The operation of delayed reservation in JET is shown in Figure 5. Let assume that a control packet has arrived at an OBS node at time  $t$ . Let the offset time is  $t_{\text{offset}}$  and the length of the payload is  $t_{\text{burst}}$ . The first bit of the corresponding data burst is expected to arrive at time  $t + t_{\text{offset}}$ . After processing the control packet, the node reserves a wavelength for the payload starting at time  $t + t_{\text{offset}} - t_{\text{OXC}}$  and ending at time  $t + t_{\text{offset}} - t_{\text{OXC}} + t_{\text{burst}}$ . At time  $t + t_{\text{offset}} - t_{\text{OXC}}$ , the OBS node instructs its OXC fabric to



configure its switching elements to carry the payload, and this operation completes just before the arrival of the first bit of the data burst. Immediate reservation protocols only permit a single outstanding reservation for each output wavelength, whereas delayed reservation schemes allow multiple setup messages to make future reservations on a given wavelength (provided these reservations, do not overlap in time).

A void is created on the output wavelength between the time slot  $t + t_{\text{setup}}$  to  $t + t_{\text{offset}} - t_{\text{OXC}}$ . In an attempt to use the voids created by the earlier setup messages, void filling algorithms are employed in JET [10].

### III. BURST SCHEDULING ALGORITHM

When a control packet arrives at a core node, a wavelength channel scheduling algorithm is used to determine a wavelength channel on an outgoing link for the corresponding data burst. The information required by the scheduler such as the expected arrival time of the data burst and its duration are obtained from the control packet. The scheduler keeps track of the availability of time slots on every wavelength channel. It selects one among several idle channels. The selection of wavelength channel needs to be done in an efficient way so as to reduce the burst loss.

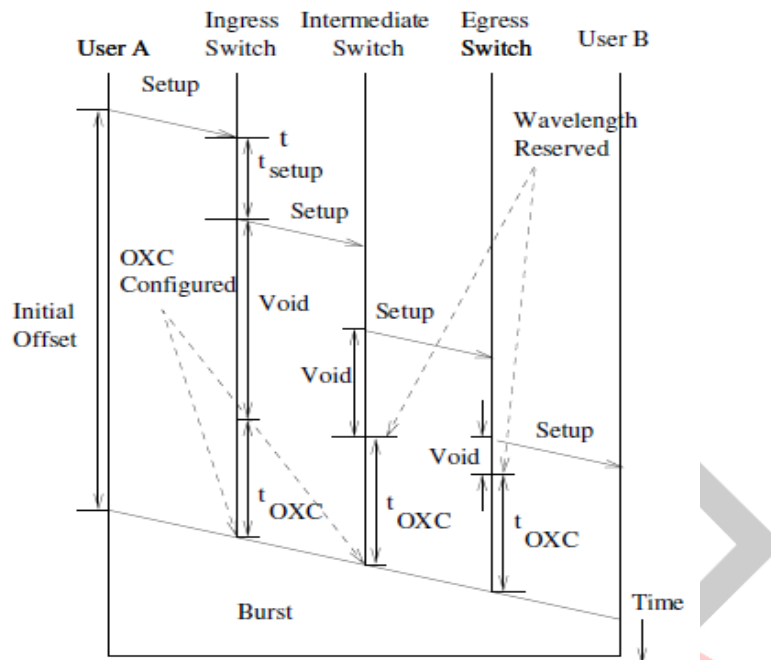

Figure 4 : Just-Enough-Time Reservation Scheme

At the same time, the scheduler must be simple and should not use any complex algorithm, because the routing nodes operate in a very high speed environment handling a large amount of burst traffic. A complex scheduling algorithm may lead to the early data burst arrival situation wherein the data burst arrives before its control packet is processed and eventually the data burst is dropped [3]. In this section we discuss various scheduling algorithms proposed in literature. These algorithms differ in their complexity and performance in terms of burst loss. A wavelength channel is said to be unscheduled at time  $t$  when no data burst is using the channel at or after time  $t$ . Algorithms which consider unscheduled channels are called Horizon algorithm. A channel is said to be unused for the duration of voids between two successive data bursts and after the last data burst assigned to the channel. Algorithms which consider voids within channels are called void filling algorithm. According to scheduling strategy used scheduling algorithms can be classified as follows:

- Horizon or without void filling.
- With void filling.

Representative of Horizon algorithms are: First Fit Unscheduled Channel (FFUC), Latest Available Unused Channel (LAUC) and that of void filling algorithms are: First Fit Unscheduled Channel with Void Filling (FFUC-VF), Latest Available Unused Channel with Void Filling (LAUC-VF) and Minimum End Void (Min-EV). Working of algorithms is illustrated with the help of Figure 6. In Figure 6, control packet arrives at a node at time  $t_{\text{CB}}$ . Duration of payload is  $t_{\text{burst}}$  and the offset time for the data burst is  $t_{\text{offset}}$ . The offset time is calculated as:

$$t_{\text{offset}} = H * t_{\text{setup}}$$

Where  $H$  is number of hops from source to destination and  $t_{\text{setup}}$  is the time required for processing and switching the control packet. The time at which the first bit of payload arrives at the node is  $t_{\text{CB}} + t_{\text{offset}}$  and the last bit at  $t_{\text{CB}} + t_{\text{offset}} + t_{\text{burst}}$ . We define unscheduled channel and void channel as following: unscheduled channel: A wavelength channel is said to be unscheduled at time  $t$  when no data burst is using the channel at or after  $t$ . void channel: If a channel is unused for duration between two successive data bursts.

#### First Fit Unscheduled Channel (FFUC)

First fit unscheduled channel (FFUC), selects an unscheduled channel for an incoming data burst. FFUC keeps the unscheduled time for each data channel. When a control packet arrives, the FFUC algorithm searches all data channels in a fixed order and assigns the data burst to the first channel that is available at or after the arrival time of the payload. In Fig. 6, when a control packet

arrives at a time  $t_{CB}$ , the scheduling algorithm searches for all unused channels. Available unscheduled channels are channel 1 and 2. FFUC selects channel 1, since this is the first available channel. And the channel is reserved for the duration

$$T_{\text{duration}} = [t_{CB} + t_{\text{offset}}; t_{CB} + t_{\text{offset}} + t_{\text{burst}}]$$

Advantage of the algorithm is speed due to the relatively small number of channels that it checks. The best implementation of the FFUC scheduling algorithm takes  $O(\log n)$  time to schedule a data burst, where  $n$  is the number of data channels. Disadvantage of the algorithm is low network resource utilization due to following reasons: (1) does not consider voids that may appear between two already scheduled data bursts as a possible place for fitting the incoming data burst. (2) Stops after first available channel [19].

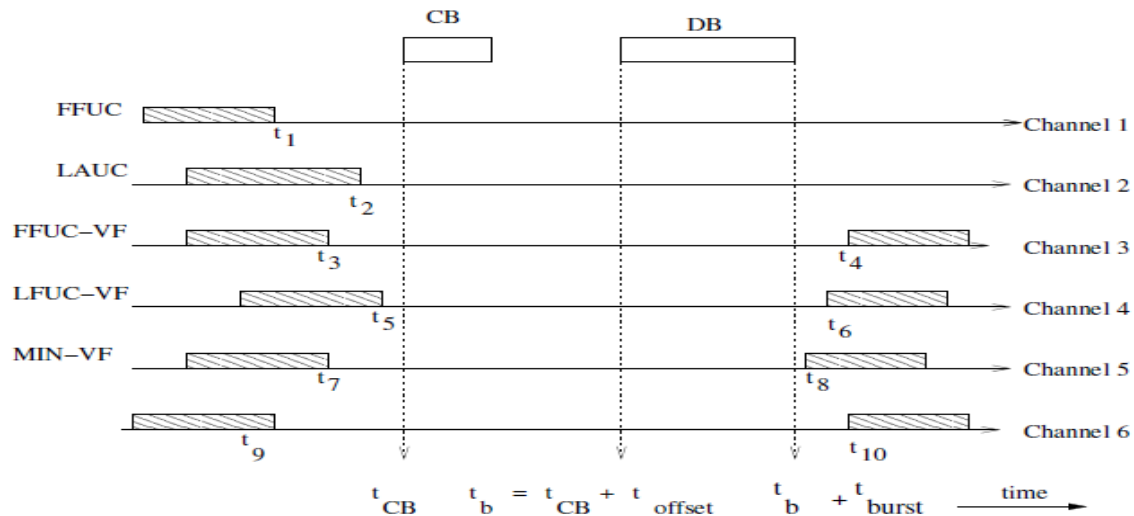

Figure 5 : Illustration of Burst Scheduling Algorithms

#### Latest Available Unscheduled Channel (LAUC)

Latest available unscheduled channel (LAUC), selects an unscheduled data channel where the void created between consecutive scheduling of data bursts is minimum. In Figure 6, channel 1 and 2 are two unscheduled channel at  $t_b$ . Scheduling on channel 1 creates a void  $(t_b - t_1)$  and in 2 is  $(t_b - t_2)$ . Since  $(t_b - t_1) > (t_b - t_2)$ , LAUC selects channel 2 for scheduling. LAUC has the same complexity as that of FFUC. In addition, LAUC utilizes the network resources better than FFUC.

#### First Fit Unscheduled Channel with Void Filling (FFUCVF)

In First fit unscheduled channel with void filling (FFUCVF), all possible voids are found and the payload is scheduled on the first available void that is suitable for transmission. In Figure 6, voids are available on the channel 3, 4, 5 and the duration of voids are  $(t_4 - t_3)$ ,  $(t_6 - t_5)$  and  $(t_8 - t_7)$ . FFUC-VF selects the channel 3 to schedule the data burst, because channel 3 is the first available void channel. If  $n$  is the number of data bursts currently scheduled on every data channel, then a binary search algorithm takes  $\log n$  time to check that the data channel is eligible or not. Thus the time complexity of the FFUC-VF algorithm is  $O(w \log n)$ , where  $w$  is the number of data channels [10].

#### Latest Available Unscheduled Channel with Void Filling (LAUC-VF)

Latest available unscheduled channel with void filling (LAUC-VF), searches all data channels to find an available void channel for the time interval  $(t_b + t_{\text{offset}})$  and  $(t_b + t_{\text{offset}} + t_{\text{burst}})$ . Then select a channel, such that placement of new data burst create minimal void between newly arrival data burst start time and previous scheduled data burst end time. In Figure 2.4, channel 3, 4, 5, 6 have such void. The difference between start time of newly arrival data burst and already scheduled data burst whose end time is prior to the start time of new data burst on the channels 3, 4, 5 and 6 are:  $(t_b + t_{\text{offset}} - t_3)$ ,  $(t_b + t_{\text{offset}} - t_4)$ ,  $(t_b + t_{\text{offset}} - t_5)$  and  $(t_b + t_{\text{offset}} - t_6)$  respectively. LAUC-VF select channel having minimum of the above time difference. So it selects channel 4 to schedule the incoming data burst. To implement LAUC-VF, switching control unit have to store usage information of all data channels. That makes LAUC-VF more complex compared to that of FFUC and LAUC. But it has higher network resource utilization [10].

#### Minimum End Void (Min-EV)

A variation of LAUC-VF algorithm is Minimum end void (Min-EV) [11]. It searches all data channels to find an available void channel to schedule the newly arrival data burst. Then, select a channel, such that placement of new data burst create minimal void between already scheduled data bursts start time and newly arrival data bursts end time [10]. In Figure 2.4, channel 3, 4, 5, 6 have such void. The difference between start time of already scheduled data burst and end time of newly arrival data burst on channel 3, 4, 5 and 6 are:  $(t_4 - (t_b + t_{\text{burst}}))$ ,  $(t_6 - (t_b + t_{\text{burst}}))$ ,  $(t_8 - (t_b + t_{\text{burst}}))$  and  $(t_{10} - (t_b + t_{\text{burst}}))$  respectively. Min-EV selects a channel having minimum of the above value. Therefore, channel 5 is selected.

## IV. CONTENTION RESOLUTION TECHNIQUES

Contention occurs when more than one data burst try to reserve the same wavelength channel on an outgoing link. In electronic network, contention is resolve by buffering the contending packets. In OBS network when contention occurs one of contending data burst is allowed to reserve the channel, for other data bursts one or a combination of the following contention resolution technique can be applied.

#### Optical Buffering

Optical buffering is achieved through the use of fiber delay lines (FDL). In optical network, fiber delay line (FDL) is currently the only way to implement optical buffering. To resolve contention using FDL, one of the contending data burst is passed through

FDL. But it has several limitations. FDL are bulky and require over a kilometer of fiber to delay a single packet for 5  $\mu\text{sec}$ , provide only a fixed delay and data leave the FDL in the same order in which they entered. Delay lines are commercially not viable due to the above drawbacks. In general, FDL can be used with other schemes to improve the performance [10].

#### Wavelength Conversion

Wavelength conversion is the process of converting a wavelength on an incoming channel to another wavelength on an outgoing channel [10]. To resolve contention using this method, a contending data bursts wavelength is shifted to another wavelength on the designated output link. Thus it increases wavelength re-usability. The concept of wavelength conversion is illustrated in Fig. 7. Assume that connections are required to be established between node pairs (C, D) and (A, D). Suppose both connections select the wavelength  $W_1$  for light path establishment. At node B, both connections try for wavelength  $W_1$  on link BD. Only one of the connections can be accepted. Let that the connection be (C, D). Since the wavelength  $W_1$  is already used, the connection (A, D) would be dropped in case of wavelength continuity constraint. However in wavelength conversion, node B would convert an incoming wavelength  $W_1$  to an available wavelength  $W_2$  on the link  $B \rightarrow D$  and the connection (A, D) would be established [11].

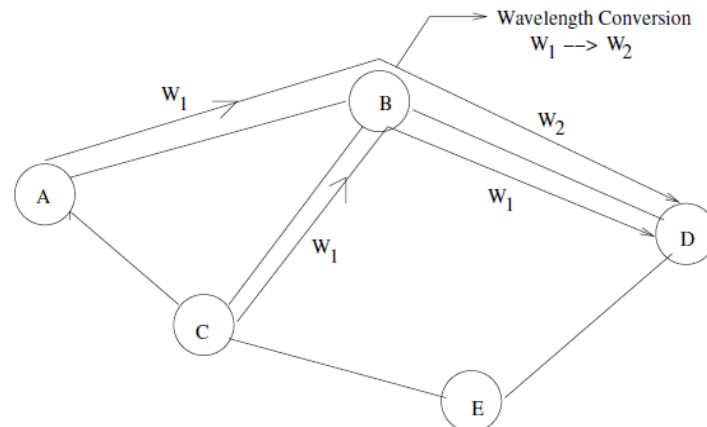

Figure 6 : Wavelength conversion

Assume that connections are required to be established between node pairs (C, D) and (A, D). Suppose both connections select the wavelength  $W_1$  for light path establishment. At node B, both connections try for wavelength  $W_1$  on link BD. Only one of the connections can be accepted. Let that the connection be (C, D). Since the wavelength  $W_1$  is already used, the connection (A, D) would be dropped in case of wavelength continuity constraint. However in wavelength conversion, node B would convert an incoming wavelength  $W_1$  to an available wavelength  $W_2$  on the link  $B \rightarrow D$  and the connection (A, D) would be established [11].

#### Deflection Routing

Deflection routing is another approach to resolve contention in OBS networks. In deflection routing one of a contending data burst is sent to a different output port and then follows an alternative route to the destination. Working of deflection routing is explained below.

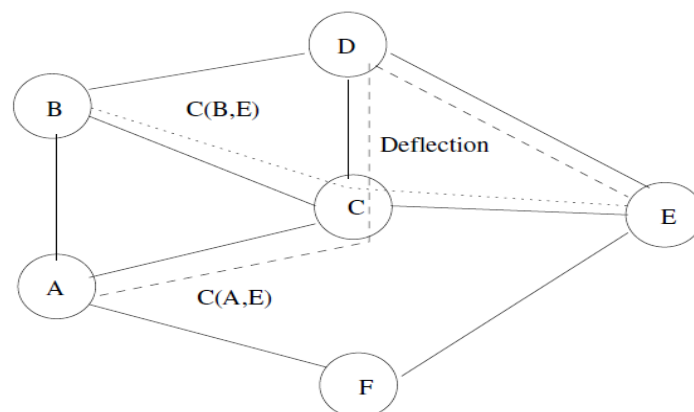

Figure 7 : Deflection routing.

We consider Fig.8 for explanation. Suppose both nodes A and B are sending data bursts we consider Fig. 8 for explanation. Suppose both nodes A and B are sending data bursts to node E. Before sending data bursts, nodes A and B send control packets (denoted as C (A, E) and C (B, E)) on control channels for bandwidth reservation for their respective data bursts. Assume, C (B, E) arrives at node C earlier than C (A, E). In this case, the output link CE is reserved by C (B, E). When C (A, E) arrives at node C, the link CE is not available. Without deflection, this data burst will be dropped. In deflection routing, node C checks other output links and selects the deflection link CD which is idle at that time. Then node D forwards B (A, E) on the link  $D \rightarrow E$  and the connection between node A and E would be established [10].

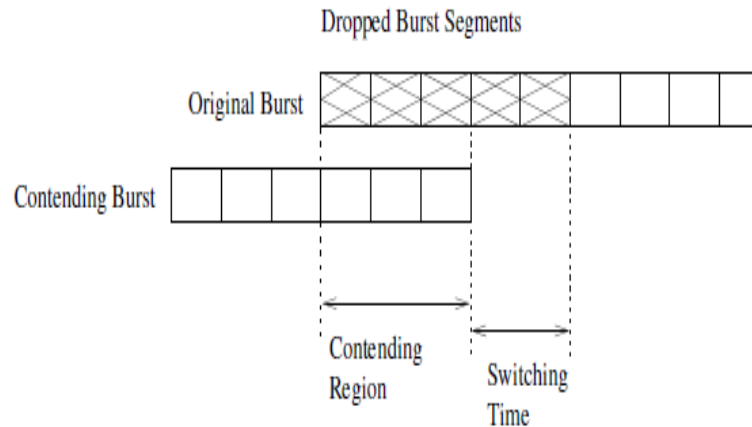

Figure 8 : Burst Segmentation

#### Burst Segmentation

Burst segmentation is a technique to reduce packet loss rather than burst loss [12]. A data burst is composed of a number of segments. When two data bursts are contending, the overlapping segments of one of the contending data burst is dropped rather than the entire data burst. The concept of burst segmentation is shown in Fig. 9. Burst segmentation gives good performance in terms of packet loss. But it requires a complex control handling to make it reality [19].

#### V. CONCLUSION

Optical burst switching is the new switching paradigm for the next generation optical network. In OBS control packets are decoupled from the data packets and are sent in different channels. Control information is sent on control channel and data packets are sent on data channels. Some of the research issues identified in OBS network are - burst assembly and disassembly, burst scheduling, contention resolution and QoS. In this paper, we have tried to aggregate the work, reported by researchers in OBS networks.

#### REFERENCES

- [1] A. K. Turuk and R. Kumar. "A Novel Scheme to Reduce Burst-Loss and Provide QoS in Optical Burst Switching Network". In proceeding ofHiPC-2004, pp. 19-22, 2004.
- [2] K. Koduru, "New Contention Resolution Techniques for Optical BurstSwitching," Master's thesis, Louisiana State University, May 2005.
- [3] S. Yoo, S. I. B. Yoo, and B. Mukherjee. All-Optical Packet Switchingfor Metropolitan Area Networks: Opportunities and Challenges. *IEEE Communications Magazine*, vol. 39, pp. 142-148,2001.
- [4] Uyles D. Black. Optical Networks: Third Generation Transport Systems.Prentice Hall PTR, 2002.
- [5] W. M. Golab and R. Boutaba. Resource Allocation in User-Controlled Circuit-Switched Optical Networks. *LNCS Springer-Verlag*, 16(12):2081 {2094, December 1998.
- [6] R. Ramaswami and K.N. Sivarajan. Routing and Wavelength Assignment in All-Optical Networks. *IEEE/ACM Transactions on Networking*, 3(5):489 {500, October 1995.
- [7] R. Ramaswami and K.N. Sivarajan. "Routing and Wavelength Assignment in All-Optical Networks", *IEEE/ACM Transactions on Networking*, vol. 3(5), pp. 489- 500, October 1995.
- [8] M. I. O. Mahony, D. Simeonidou, D. Hunter, and A. Tzanakaki. The Application of Optical Packet Switching in Future Communication Networks. *IEEE Communications Magazine*, vol. 39, pp. 128-135, March 2001.
- [9] D. Blumenthal, P. Prucnal, and I. Sauer, "Photonic Packet Switches Architectures and Experimental Implementations," In Proceeding of IEEE, vol. 82, pp. 1650-1667, November 1994.
- [10] Mrinal Nandi, "A Technique to Minimize Contention in Optical Burst Switching Networks".
- [11] S. Yao, B. Mukherjee, and S. Dixit, "Advances in Photonic Packet Switching: An Overview", *IEEE Communications Magazine*, vol. 38, pp. 84 -94, February 2000.
- [12] D.K.Hunter, M.C.Chia, and I.Andonovic. Buffering in Optical Packet Switches. *IEEE/OSA Journal of Lightwave Technology*, voi. 16(12), pp. 2081- 2094, December 1998.
- [13] J. Turner, "Terabit Burst Switching," *Journal of High Speed Networks*, vol.8, pp. 3-16, January 1999.
- [14] M. Yoo and C. Qiao, "A Novel Switching Paradigm for Buffer-Less WDM Networks," In Optical Fiber Communication Conference (OFC), San Diego, CA, pp. 177-179, February 1999.
- [15] M. Yoo and C. Qiao. Choices, "Features and Issues in Optical Burst Switching (OBS)," *Optical Networking Magazine*, vol. 1(2), pp. 36-44, April 1999.



- [16] S. Verma, H. Chaskar, and R. Ravikanth, "Optical Burst Switching: A Viable Solution for Terabit IP Backbone," IEEE Network, pp. 48-53, November/December 2000.]
- [17] J. Teng and G. N. Rouskas, "A Comparison of the JIT, JET, and Horizon Wavelength Reservation Schemes on a Single OBS Node," In Proceedings of the First Workshop on Optical Burst Switching, October 2003.
- [18] C. Qiao and M. Yoo, "Optical Burst Switching (OBS) - A New Paradigm for an Optical Internet," Journal of High Speed Networks (JHSN), vol. 8(1), pp. 69-84, 1999.
- [19] Y. Chen, C. Qiao, and X. Yu, "Optical Burst Switching: A New Area in Optical Networking Research," IEEE Network Magazine, vol. 18(3), pp. 16-23, 2004.
- [20] J. P. Jue, V. M. Vokkarane, "Optical Burst Switching," Springer Science, 2005.
- [21] B. Lannoo, Jan Cheyys, Erik Van Breusegem, Ann Ackaert, Mario Pickavet, and Piet Demeester, "A Performance Study of Different OBS Scheduler Implementations," In Proceeding of Symposium IEEE/LEOS Benelux Chapter, Amsterdam, 2002.
- [22] C. Siva Ram Murthy and Mohan Gurusamy, "WDM Optical Networks: Concepts, Design and Algorithms," Prentice Hall PTR, November 2001.
- [23] M. Yoo and C. Qiao, "A New Optical Burst Switching Protocol for Supporting Quality of Service," In Proceeding of SPIE, All Optical Networking: Architecture, Control, Network Issues, pp. 396-405, November 1998.
- [24] P. DU, "QoS Control and Performance Improvement Methods for Optical Burst Switching Networks," PhD thesis, Department of Informatics, School of Multidisciplinary Sciences, The Graduate University for Advanced Studies (SOKENDAI), March 2007.
- [25] V. Vokkarane, Q. Zhang, J. P. Jue, and B. Chen, "Generalized Burst Assembly and Scheduling Techniques for QoS Support to Optical Burst-Switched Networks," In Proceedings of GLOBECOM, pp. 2747-2751, November 2002.
- [26] V. Vokkarane, J. P. Jue, and S. Sitaraman, "Burst Segmentation: An Approach for Reducing Packet Loss in Optical Burst Switched Networks," In Proceeding of IEEE ICC 2002, pp. 2673-2677, 2002.

